



**KIESELMANN**  
FLUID PROCESS GROUP

## Operating instructions

- Translation of the Original -

### Vacuum valve

#### Type 6162

weight-loaded, pneum. operation  
DN 50 - DN 250

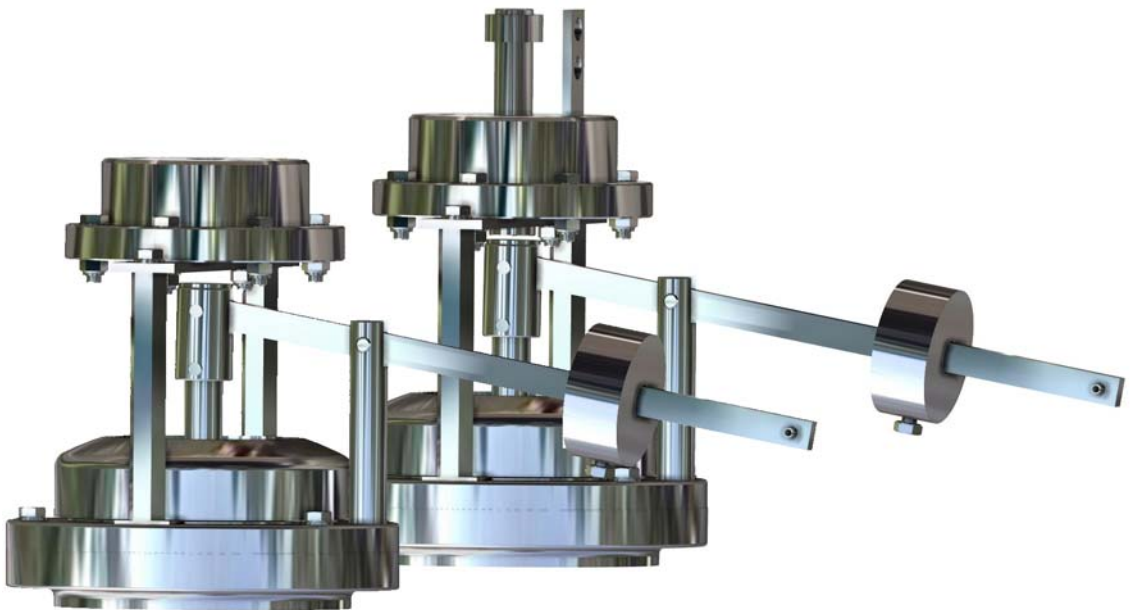

English **GBR**

8.9.15

**KIESELMANN GmbH**  
Paul-Kieselmann-Str.4-10  
D - 75438 Knittlingen

☎ +49 (0) 7043 371-0 • Fax: +49 (0) 7043 371-125  
www.kieselmann.de • sales@kieselmann.de

1.	General safety instructions .....	2
1.1	Information for your safety .....	2
1.2	Marking of security instructions in the operating manual .....	2
1.3	Designated use .....	2
1.4	Personnel .....	2
1.5	Modifications, spare parts, accessories .....	2
1.6	General instructions .....	2
2.	Safety instructions .....	3
2.1	Field of application .....	3
2.2	General safety instructions .....	3
2.3	General notes .....	3
3.	Function.....	3
3.1	Description of function .....	3
4.	Installation informations.....	3
4.1	Installation instructions.....	3
4.2	Welding guidelines .....	3
5.	Maintenance.....	4
5.1	Maintenance .....	4
5.2	Cleaning.....	4
6.	Technical Data .....	4
7.	Identification .....	5
8.	Pressure setting .....	5
9.	Disassembly and assembly.....	6
9.1	Disassembly Pos. (4), (5).....	6
9.2	Assembly .....	7
10.	Drawings and Dimensions.....	8
10.1	construction dimensions .....	9
11.	Performance chart.....	9
12.	Valve type.....	9
13.	Spare Parts List.....	10

# 1. General safety instructions

## 1.1 Information for your safety

We are pleased that you have decided for a high-class KIESELMANN product. With correct application and adequate maintenance, our products provide long time and reliable operation.



Before installation and initiation, please carefully read this instruction manual and the security advices contained in it. This guarantees reliable and safe operation of this product and your plant respectively. Please note that an incorrect application of the process components may lead to great material damages and personal injury.

**In case of damages caused by non observance of this instruction manual, incorrect initiation, handling or external interference, guarantee and warranty will lapse!**

Our products are produced, mounted and tested with high diligence. However, if there is still a reason for complaint, we will naturally try to give you entire satisfaction within the scope of our warranty. We will be at your disposal also after expiration of the warranty. In addition, you will also find all necessary instructions and spare part data for maintenance in this instruction manual. If you don't want to carry out the maintenance by yourself, our KIESELMANN service team will naturally be at your disposal.

## 1.2 Marking of security instructions in the operating manual

Hints are available in the chapter "safety instructions" or directly before the respective operation instruction. The hints are highlighted with a danger symbol and a signal word. Texts beside these symbols have to be read and adhered to by all means. Please continue with the text and with the handling at the valve only afterwards.

Symbol	Signal word	Meaning
	<b>DANGER</b>	Imminent danger which may cause severe personal injury or death.
	<b>ATTENTION</b>	Dangerous situation which may cause slight personal injury or material damages.
	<b>NOTE</b>	Marks application hints and other information which is particularly useful.

## 1.3 Designated use

The fitting is designed exclusively for the purposes described below. Using the fitting for purposes other than those mentioned is considered contrary to its designated use. KIESELMANN cannot be held liable for any damage resulting from such use. The risk of such misuse lies entirely with the user. The prerequisite for the reliable and safe operation of the fitting is proper transportation and storage as well as competent installation and assembly.

Operating the fitting within the limits of its designated use also involves observing the operating, inspection and maintenance instructions.

## 1.4 Personnel

Personnel entrusted with the operation and maintenance of the tank safety system must have the suitable qualification to carry out their tasks. They must be informed about possible dangers and must understand and observe the safety instructions given in the relevant manual. Only allow qualified personnel to make electrical connections.

## 1.5 Modifications, spare parts, accessories

Unauthorized modifications, additions or conversions which affect the safety of the fitting are not permitted. Safety devices must not be bypassed, removed or made inactive. Only use original spare parts and accessories recommended by the manufacturer.

## 1.6 General instructions

The user is obliged to operate the fitting only when it is in good working order. In addition to the instructions given in the operating manual, please observe the following:

- relevant accident prevention regulations
- generally accepted safety regulations
- regulations effective in the country of installation
- working and safety instructions effective in the user's plant.

## 2. Safety instructions

### 2.1 Field of application

This vacuum valve is used to prevent underpressures in tanks and vessels for food and beverage industry, pharmaceutical and chemical industries as well as in biotechnology.



#### ATTENTION

- To avoid danger and damage, the fitting must be used in accordance with the safety instructions and technical data contained in the operating instructions.

### 2.2 General safety instructions



#### DANGER

- Dismantling the valve or valve assemblies from the plant can cause injuries from fluids or gases flowing out.  
Dismantle the valve or valve assembly only when the plant has been rendered pressure-less and free of liquid and gas.
- Referring to the used sealing materials the vacuum valves are suitable for a minimum operating temperature at -10 °C. An operation at low process or ambient temperatures may affect the safety function.  
Therefore, appropriate measures shall be taken for an operation at temperatures below +5 °C.



#### ATTENTION

- The action of external force on the lever mechanism results in changes in the opening characteristics. This can result in damage to the tanks.
- Internal or external dirt may impair the function of the fitting or the safety equipment. Therefore the fitting must be operated in a way that protects it from external influences and it must be cleaned and maintained at regular intervals.
- Remove transport insurance before initial operation.
- Follow the instructions of the welding guidelines.

### 2.3 General notes



#### NOTE

All data are in line with the current state of development. Subject to change as a result of technical progress.

## 3. Function

### 3.1 Description of function

The function of the vacuum valve is to prevent inadmissible pressure shortfalls ( $\leq 30$  mbar absolute pressure), in tanks and containers, which can result in damage. At underpressure, the valve opens to the atmosphere. The pressure in the tank is brought to the atmospheric pressure by the inflowing air. When the pressures become equal, the valve closes by the force of its weight without any external energy. The flow capacities referred to the relevant underpressure are shown in the capacity diagram (see "11. Performance chart" on page 9).

In addition, the valve can be operated via a pneumatic actuator (DN250 only till max. 2 bar tank pressure). The position of the actuator can be retrieved via sensors which are mounted at a sensor mounting (optional).

## 4. Installation informations

### 4.1 Installation instructions

#### Fitting position

The vacuum valve is generally to be installed vertically (see figure on the right).

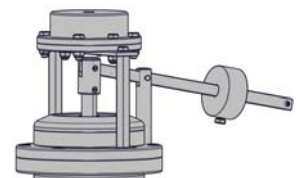

### 4.2 Welding guidelines

Sealing elements integrated in weld components must generally be removed prior to welding. To prevent damage, welding should be undertaken by certified personnel (EN287). Use the TIG (tungsten inert gas) welding process.



#### NOTE

Impurities can cause damage to the seals. Clean inside areas prior to assembly.

## 5. Maintenance

### 5.1 Maintenance

The maintenance intervals depend on the operating conditions "temperature, temperature-intervals, medium, cleaning medium, pressure and opening frequency". We recommend replacing the seals every 2 years. The user, however should establish appropriate maintenance intervals according to the condition of the seals.



#### NOTE

EPDM; Viton; k-flex; NBR; HNBR →  
Silicone →  
Thread →

#### Lubricant recommendation

Klüber Paraliq GTE703\*  
Klüber Sintheso pro AA2\*  
Interflon Food\*

*\*) It is only permitted to use approved lubricants, if the respective fitting is used for the production of food or drink. Please observe the relevant safety data sheets of the manufacturers of lubricants.*

### 5.2 Cleaning

A complete cleaning of all the parts that have come in contact with the product is only possible in the dismantled state.

The cleaning of the fitting surfaces that touch the product takes place with the tank cleaning. The cleaning of the external surfaces must be performed at regular intervals. The cleaning cycles are to be defined by the user.

## 6. Technical Data

<b>Model:</b>	Aeration valve, weight-loaded, pneumatic operation, optional with heating cartridge and sensor mounting
<b>Valve size:</b>	DN 50 - DN 250
<b>Connections:</b>	- Flange connection - Flange with welding end DIN EN 10357
<b>Temperature range:</b>	-10° bis +95°C medium-dependent (note the general safety instructions 3.2 / page 3)
<b>Material in product contact:</b>	Stainless steel: <ul style="list-style-type: none"> <li>• 1.4301 / AISI304</li> <li>• 1.4404 / AISI316L</li> </ul> Surfaces: <ul style="list-style-type: none"> <li>• Ra &lt; 0,8µm mat finish</li> </ul> Seal material: <ul style="list-style-type: none"> <li>• DN50-DN200 NBR, VMQ (Silicone)</li> <li>• DN250 NBR, EPDM</li> </ul>

DN	50	65	80	100	125	150	200	250
Operating pressure max. (bar)	8	10	10	10	10	10	10	10
Counterpressure at the actuator* max. (bar)	6	6	5	4	2	1,5	1	1,5

*\*max. counterpressure at the pneum. actuator (A) at which the drive can still reliably open*

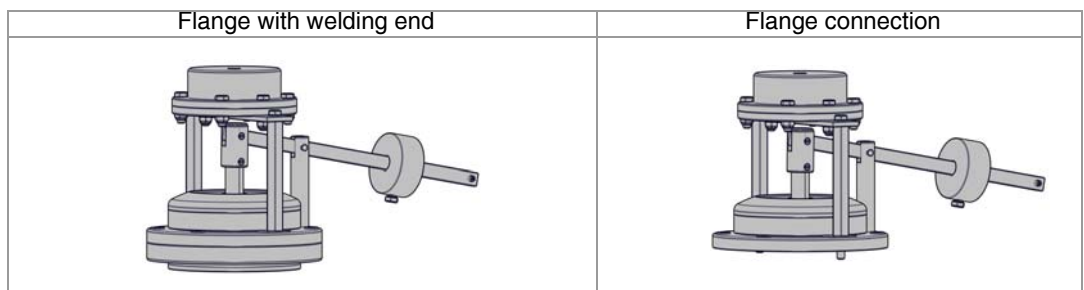

## 7. Identification

A = Designation  
 B = Notified body  
 C = Manufacturer  
 D = Nominal diameter  
 E = max. allowable pressure  
 F = min. / max. allowable Temperature  
 G = Material  
 H = Order number  
 I = Set pressure in mbar  
 J = Set pressure in mm WC (Water column)  
 K = Date of manufacture

K1= lasered  
 K2= label

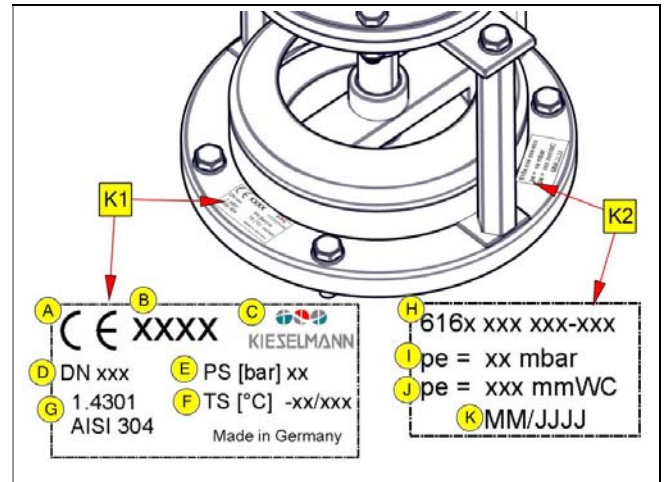

## 8. Pressure setting

The vacuum valve is set at the factory, by correspondingly positioning the weight (12), to an underpressure of 3 mbar. At this underpressure, the valve opens to the atmosphere.



### NOTE

If the position of the weight (12) is changed towards direction (B), the closing function is not guaranteed any more.  
 If the position of the weight (12) is changed towards direction (A), then the water column (Wc) increase on the maximum water column  $W_{c_{max}}$ .

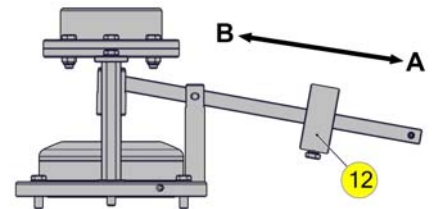

DN	50	65	80	100	125	150	200	250
							long lever / short lever	
$W_{c_{min.}}$ (mm)	30	30	30	30	30	30 / 30	30 / 30	30 / 30
$W_{c_{max.}}$ (mm)	150	50	200	150	240	320 / 120	125 / 100	370 / 80

## 9. Disassembly and assembly

### 9.1 Disassembly Pos. (4), (5)

#### ➤ Figure: Vacuum valve DN100 with heating cartridge and sensor mounting

- Fig. 1
- Remove the control air (LA) from the actuator (A).
  - Unscrew the hexagon screws (16) and (17). Remove actuator (A) and plate (18).
  - Unscrew the bolts (20) and screws (14a).
  - Remove the complete valve and dismount the O-Ring (5).
  - Unscrew the set screw (8) and remove the complete valve plate from the housing (1)
  - Clamp the complete valve plate at the outer diameter of plate (2) in the vise (with soft jaws).
  - With a round rod M1 ( $\varnothing 6$ ), in the drilled hole (B), unscrew the bolt (7).
  - Remove the O-ring (4) from the groove.
  - Thoroughly clean of grease the thread in the plate (2) and bolt (7).

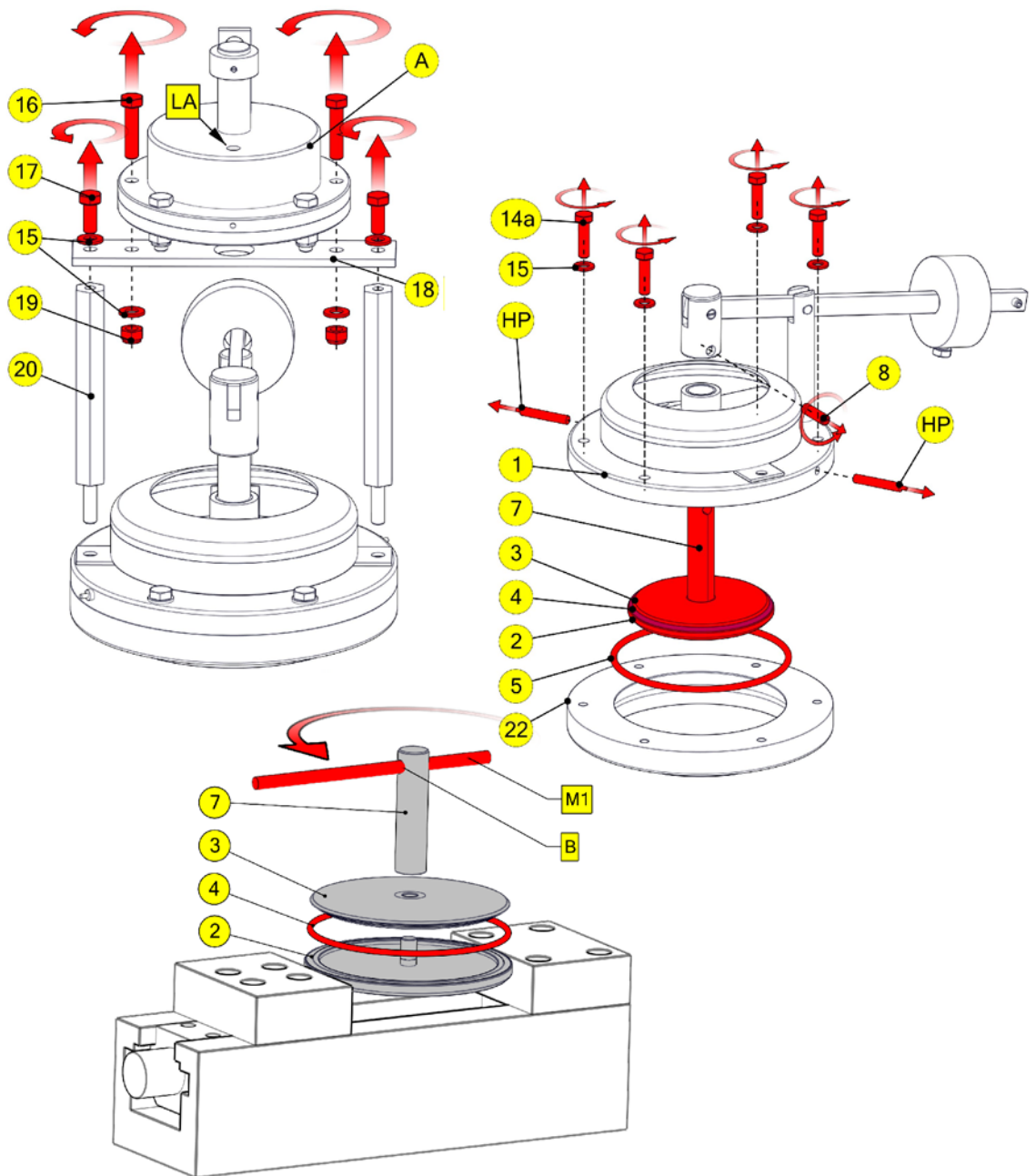

Fig. 1



### 🔧 Exchanging seals Item. (A3), (A7)

- Fig 2
- Unscrew screws (A11) and set screw (A13). Remove the control cam (A12).
  - Pull off the housing bottom (A1) with the spring (A6) from the stud (A5) axially.
  - Dismantle the stud (A5) with the piston (A4) from the casing (A2).
  - Remove the locking ring (A9) and pull off the piston (A4) from the stud (A5).
  - Dismantle the seals (A3) and (A7).

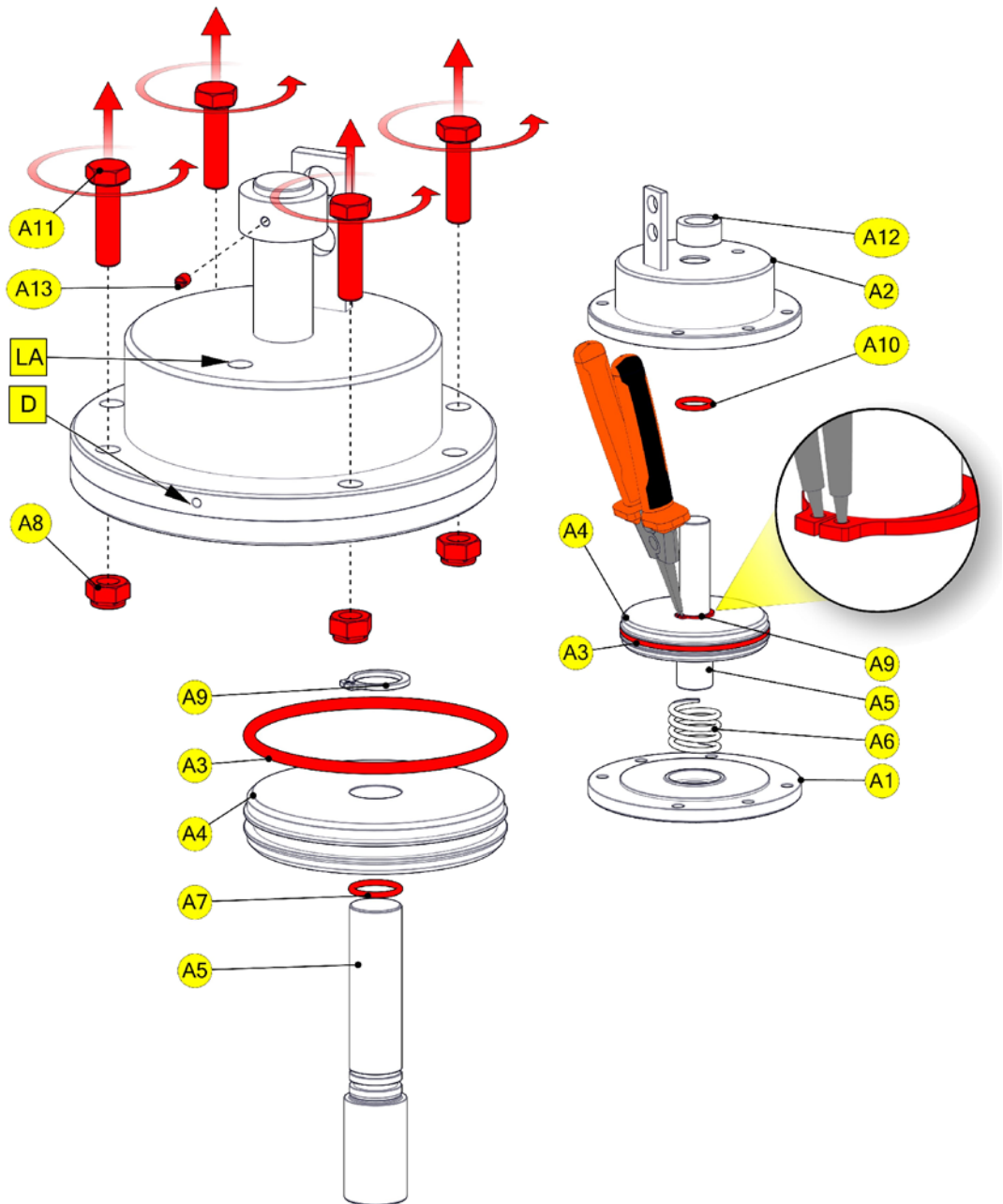

Fig. 2

### 9.2 Assembly

- Thoroughly clean and slightly lubricate mounting areas and running surfaces. (see "5.1 Maintenance" on page 4).
- Assemble in reverse order.



#### NOTE

Secure the threaded joint of plate (2) and bolt (7) with a removable screw locking device.

Test proper performance in the operating state according to the specified performance data.



# 10. Drawings and Dimensions

➤ Figure: Vacuum valve DN100 with heating cartridge and sensor mounting

- 1 Housing
- 2 Plate bottom
- 3 Plate top
- 4 O-Ring
- 5 O-Ring
- 6 Plain bearing
- 7 Bolt
- 8 Set screw
- 9 Link
- 10 Lever
- 11 Set screw
- 12 Weight
- 13 Dowel pin
- 14 a) Hexagon screw  
b) Hexagon screw
- 15 Disc
- 16 Hexagon screw
- 17 Hexagon screw
- 18 Plate
- 19 Nut
- 20 Bolt
- 21 splash protection
- 22 Flange (optional)
  
- A1 Housing bottom
- A2 Housing
- A3 O-Ring
- A4 Piston
- A5 Stud
- A6 Pressure spring
- A7 O-Ring
- A8 Prevailing torque type
- A9 Circlip
- A10 Hexagon screw
- A11 O-Ring
- A12 Control cam
- A13 Set screw
  
- S Sensor mounting (optional)
- HP Heating cartridge (optional)

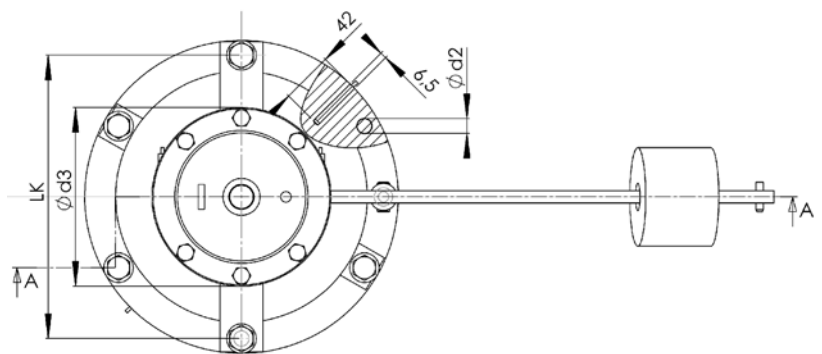
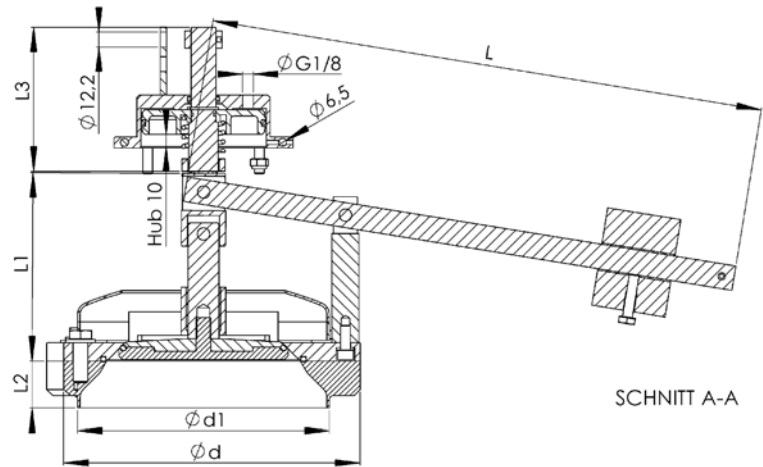
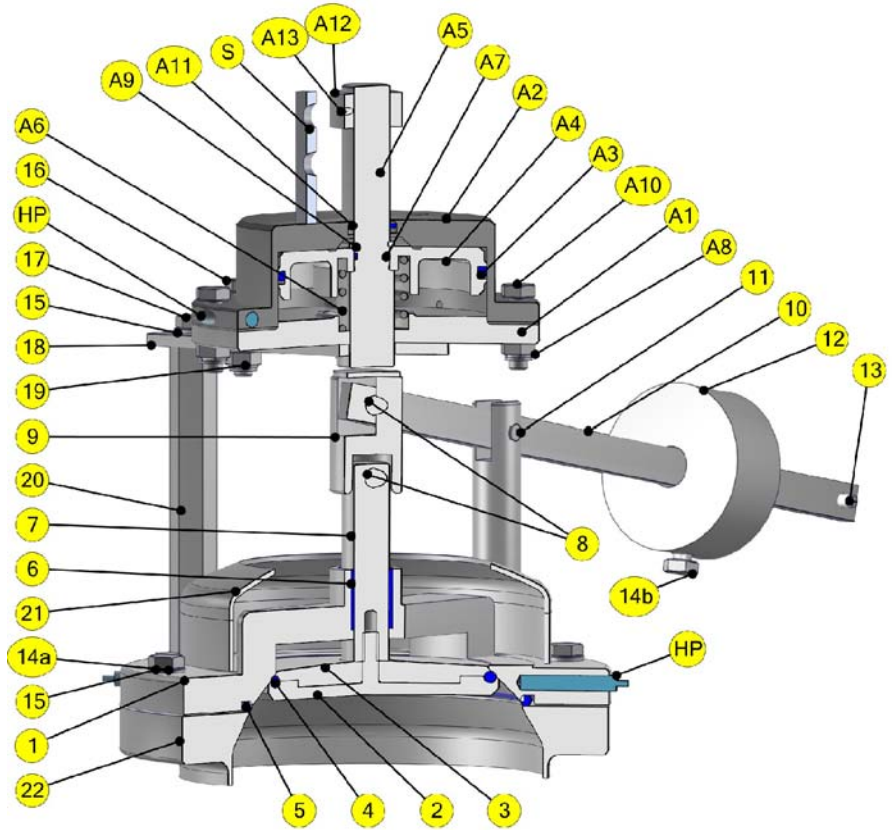

Fig. 3

## 10.1 construction dimensions

	DN50	DN65	DN80	DN100	DN125	DN150	DN200	DN250
						long lever / short lever		
L	240	250	350	350	450	680 / 450	700 / 450	700 / 500
L1	108	122	134	130	150	152	195,5	222
L2	28	29	34	30	38	39	40	55
L3	116,5	116,5	116,5	116,5	116,5	116,5	116,5	116,5
d	Ø 129	Ø 154	Ø 204	Ø 204	Ø 254	Ø 304	Ø 326	Ø 406
d1	Ø 85x2	Ø 104x2	Ø 129x2	Ø 154x2	Ø 204x2	Ø 254x2	Ø 304x2,5	Ø 403x3
d2	Ø 6,4	Ø 8,5	Ø 8,5	Ø 8,5	Ø 13	Ø 13	Ø 13	Ø 13
d3	Ø 145	Ø 145	Ø 145	Ø 145	Ø 145	Ø 145	Ø 145	Ø 145
Lk	Ø 115	Ø 130	Ø 160	Ø 180	Ø 230	Ø 260	Ø 300	Ø 355

Measures in mm

Tab.1

## 11. Performance chart



Diagramm. 1

## 12. Valve type

- |                 |   |
|-----------------|---|
| 6162 DN 000-xxx | <ul style="list-style-type: none"> <li>- Vacuum valve, weight-loaded, pneumatic operation, for vertical installation</li> <li>- with welding flange</li> </ul>  |
| 6162 DN 040-xxx | <ul style="list-style-type: none"> <li>- Vacuum valve, weight-loaded, pneumatic operation, for vertical installation</li> <li>- without welding flange</li> </ul>   |
| 6162 DN 140-xxx | <ul style="list-style-type: none"> <li>- Vacuum valve, weight-loaded, pneumatic operation, for vertical installation</li> <li>- without welding flange</li> <li>- with sensor mounting</li> </ul>                     |
| 6162 DN 090-xxx | <ul style="list-style-type: none"> <li>- Vacuum valve, weight-loaded, pneumatic operation, for vertical installation</li> <li>- without welding flange</li> <li>- heatable</li> <li>- with sensor mounting</li> </ul> |

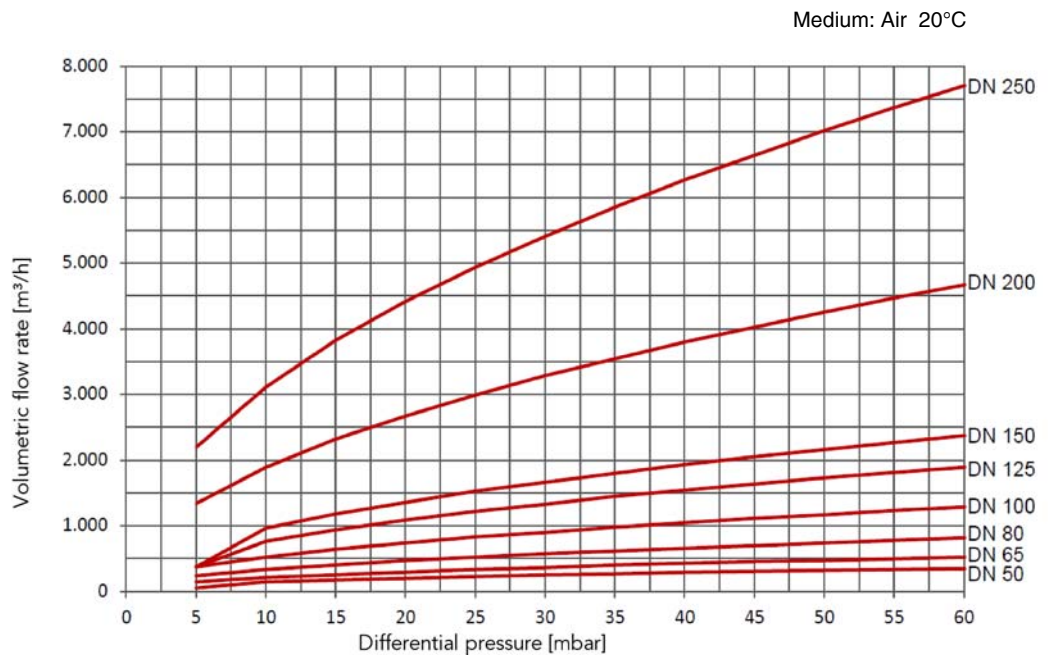
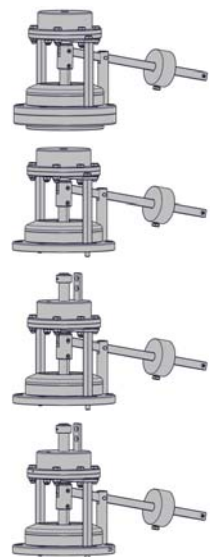

Vacuum valve Type: 6162xxxxxx-xxx

### 13. Spare Parts List

		DN 50	DN 65	DN 80	DN 100	DN 125	DN 150	DN 200	DN 250
1	Housing	6161 050 002-02x	6161 065 002-02x	6161 080 002-02x	6161 100 002-02x	6161 125 002-02x	6161 150 002-02x	6161 200 002-02x	6161 250 002-02x
2	Plate bottom	6161 050 018-021	6161 065 018-021	6161 080 018-021	6161 100 018-021	6161 125 018-021	6161 150 018-021	6161 200 018-021	6161 250 018-021
3	Plate	6161 050 019-021	6161 065 019-021	6161 080 019-021	6161 100 019-021	6161 125 019-021	6161 150 019-021	6161 200 019-021	6161 250 019-021
4	O-Ring	2304 050 050-052 VMQ 70°Sh.	2304 065 050-052 VMQ 70°Sh.	2304 080 050-052 VMQ 70°Sh.	2304 100 050-052 VMQ 70°Sh.	2304 125 050-052 VMQ 70°Sh.	2304 150 050-052 VMQ 70°Sh.	2304 200 050-052 VMQ 70°Sh.	2304 250 050-054 EPDM 70°Sh.
5	O-Ring NBR 70°Sh.	2304 080 040-055	2304 090 035-055	2304 113 035-055	2304 130 045-055	2304 153 045-055	2304 180 050-055	2304 265 060-055	2304 300 040-055
6	Plain bearing	8050 015 010-060	8050 023 020-060	8050 023 020-060	8050 023 020-060	8050 023 020-060	8050 027 024-060	8050 034 030-060	8050 034 030-060
7	Bolt	6161 050 020-021	6161 065 020-021	6161 080 020-021	6161 100 020-021	6161 125 020-021	6161 150 020-021	6161 200 020-021	6161 250 020-021
8	Set screw (2x)	6161 050 022-020	6161 065 022-020	6161 065 022-020	6161 100 022-020	6161 125 022-020	6161 150 022-020	6161 200 022-020	6161 200 022-020
9	Link	6161 050 006-02x	6161 065 006-02x	6161 080 006-02x	6161 100 006-02x	6161 125 006-02x	6161 150 006-02x	6161 200 006-02x	6161 200 006-02x
10	Lever - long Lever - short	6161 050 004-02x -	6161 065 004-02x -	6161 080 004-02x -	6161 100 004-02x -	6161 125 004-02x -	6161 150 004-02x 6161 150 007-02x	6161 200 004-02x 6161 200 016-02x	6161 250 004-02x 6161 250 005-02x
11	Set screw	6161 050 021-020	6161 065 021-020	6161 065 021-020	6161 100 021-020	6161 125 021-020	6161 150 021-020	6161 200 021-020	6161 200 021-020
12	Weight	6161 050 005-02x	6161 065 005-02x	6161 080 005-02x	6161 100 005-02x	6161 150 005-02x	6161 150 005-02x	6161 150 005-02x	6155 080 003-02x
13	Dowel pin	8126 060 020-020	8126 060 020-020	8126 060 020-020	8126 060 020-020	8126 060 024-020	8126 060 020-020	8126 060 020-020	8126 060 024-020
14a	Hexagon screw DIN933	8106 006 025-020 M6x25 (4x)	8106 008 025-020 M8x25 (4x)	8106 008 030-020 M8x30 (4x)	8106 008 030-020 M8x30 (6x)	8106 012 030-020 M12x30 (6x)	8106 012 035-020 M12x35 (6x)	8106 012 040-020 M12x40 (8x)	8106 012 040-020 M12x40 (8x)
14b	Hexagon screw DIN933	8106 006 020-020 M6x20	8106 006 030-020 M6x30	8106 006 030-020 M6x30	8106 008 030-020 M8x30	8106 008 035-020 M8x35	8106 008 050-020 M8x50	8106 008 060-020 M8x60	8105 010 070-020 M10x70
15	Disc DIN125	8071 064 001-020 A6,4 (4x)	8071 084 001-020 A8,4 (4x)	8071 084 001-020 A8,4 (4x)	8071 084 001-020 A8,4 (6x)	8071 130 001-020 A13 (6x)	8071 130 001-020 A13 (6x)	8071 130 001-020 A13 (8x)	8071 130 001-020 A13 (8x)
16	Hexagon screw DIN933	8106 008 035-020 M8x35	8106 008 035-020 M8x35	8106 008 035-020 M8x35	8106 008 035-020 M8x35	8106 008 035-020 M8x35	8106 008 035-020 M8x35	8106 008 035-020 M8x35	8106 008 035-020 M8x35
17	Hexagon screw DIN933	8106 008 030-020 M8x30 (2)	8106 008 030-020 M8x30 (2)	8106 008 020-020 M8x30 (2)	8106 008 020-020 M8x30 (2)	8106 012 030-020 M12x30 (2)	8106 012 035-020 M12x35 (2)	8106 012 025-020 M12x25 (2)	8106 012 025-020 M12x25 (2)
18	Plate	-	-	-	6162 100 002-02x	6162 125 002-02x	6162 150 004-02x	6162 200 002-02x	6162 250 002-02x
19	Nut (2x)	8115 008 000-020	8115 008 000-020	8115 008 000-020	8115 008 000-020	8115 012 000-020	8115 012 000-020	8115 012 000-020	8115 012 000-020
20	Threaded bot/ Bracket	-	-	-	6162 100 001-02x	6162 125 001-02x	6162 150 003-02x	6162 200 003-02x	6162 125 001-02x
21	Splash protection	6162 050 015-02x	6162 065 015-02x	6162 080 015-02x	6162 100 015-02x	6162 125 015-02x	6162 150 015-02x	6162 200 015-02x	6162 250 015-02x
22	Flange	6161 050 001-02x	6161 065 001-02x	6161 080 001-02x	6161 100 001-02x	6161 125 001-02x	6161 150 001-02x	6161 200 001-02x	6161 250 001-02x
HP	Heating cartridge optional	8615 481 001-000 (2x)	8615 481 001-000 (2x)	8615 481 001-000 (2x)	8615 481 001-000 (2x)	8615 481 001-000 (2x)	8615 481 001-000 (4x)	8615 481 001-000 (4x)	8615 481 001-000 (4x)

	Actuator for vacuum valve	DN50 - DN200		DN250
		A	Actuator -with sensor mounting Actuator - with sensor mounting, heatable Actuator - without sensor mounting Actuator - without sensor mounting, heatable	5000 048 050-02x 5000 048 115-02x 5000 048 000-02x -
A1	Housing bottom - for actuator without sensor mounting Housing bottom - for actuator with sensor mounting	5000 048 002-022 5000 048 052-022	- 5000 079 052-022	
A2	Housing - without sensor mounting Housing - without sensor mounting, heatable Housing - with sensor mounting Housing - with sensor mounting, heatable	5000 048 001-022 - 5000 048 051-022 5000 048 118-022	- - 5000 079 051-022 -	
A3	O-Ring	2304 089 045-055 Ø98x4,5	2304 150 045-055 Ø150x4,5	
A4	Piston	5000 048 006-020	5000 079 056-011	
A5	Stud - without sensor mounting Stud - with sensor mounting	5000 048 003-020 5000 048 054-011	5000 079 053-020 -	
A6	Pressure spring VD288 K11	8150 288 075-031	8152 032 005-031	
A7	O-Ring Ø16x2	2304 016 020-055	2304016020-055	
A8	Prevailing torque type DIN985	8115 008 000-020	8115012000-020	
A9	Circlip DIN471	8084 020 175-009	8084020175-009	
A10	O-Ring Ø19x3,5 - for actuator with sensor mounting	2304 019 035-171	-	
A11	Hexagon screw DIN933	8106 008 030-020	8106 012 035-020	
A12	Control cam - for actuator with sensor mounting	5200 065 008-021	5200 065 008-021	
A13	Set screw DIN551 - for actuator with sensor mounting	8087 004 005-020	8087 004 005-020	
HP	Heating cartridge optional (2x)	8615 481 001-000	8615 481 001-000	

Code Material Exterior Surfaces: *xxxx xxx xxx-020 - 1.4301 - bright turned*  
*xxxx xxx xxx-021 - 1.4301 - E-polished*  
*xxxx xxx xxx-022 - 1.4301 - unpolished, glass-bead blasted*

Vacuum valve Type: 6162xxxxxx-xxx