



guth ventile
FLUID PROCESS GROUP

Translation of the original

Operating instruction

Safety valves

Type 6146 - 6151

for gas

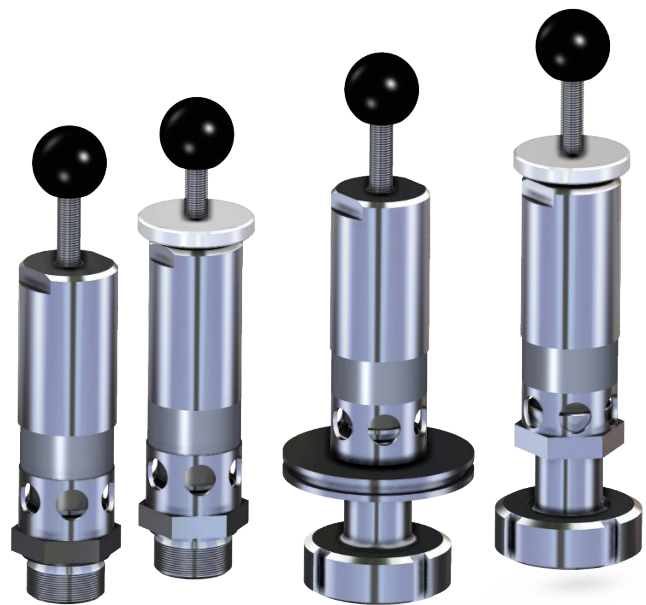

Threaded connection Type 6146; 6148; 6150

Liner/nut connection Type 6147; 6149; 6151



Guth Ventiltechnik GmbH

Horstring 16
76829 Landau

 +49(0) 6341 5105-0 •  +49(0) 6341 5105-85
www.guth-vt.de • sales@guth-vt.de

Copyright: © FLUID PROCESS GROUP

Guth Ventiltechnik GmbH is responsible for the content, completeness and correctness of the document.

Table of contents

1	General informations	4
1.1	Informations for your safety	4
1.2	Marking of security instructions.....	4
1.3	General designated use	4
1.4	Personnel.....	4
1.5	Modifications, spare parts, accessories	4
1.6	General instructions	5
2	Safety instructions.....	6
2.1	Intended use	6
2.2	General notes.....	6
2.3	General safety instructions.....	6
3	Delivery, transport and storage	7
3.1	Delivery.....	7
3.2	Transport.....	7
3.3	Storage.....	7
4	Specification.....	8
4.1	Valve types.....	8
5	Function and operation	9
5.1	Description of function.....	9
5.2	Commissioning, service and maintenance.....	9
5.2.1	Commissioning.....	9
5.2.2	Service.....	10
5.2.3	Cleaning	10
6	Technical data	11
6.1	Safety valves.....	11
6.2	Identification.....	11
7	Disassembly and assembly	12
7.1	Disassembly.....	12
7.2	Assembly	12
8	Drawings and dimensions	14
8.1	Design: seal disc.....	14
8.2	Design: O-Ring	15
8.3	Dimensions	16
9	Characteristic curves	20
9.1	Opening & closing characteristics.....	20
9.2	Blow-off performance chart.....	20
10	Appendix	24

1 General informations

1.1 Informations for your safety

We are pleased that you have decided for a high-class Guth Ventiltechnik GmbH product. With correct application and adequate maintenance, our products provide long time and reliable operation.





Before installation and initiation, please carefully read this instruction manual and the security advices contained in it. This guarantees reliable and safe operation of this product and your plant respectively. Please note that an incorrect application of the process components may lead to great material damages and personal injury.

In case of damages caused by non observance of this instruction manual, incorrect initiation, handling or external interference, guarantee and warranty will lapse!

Our products are produced, mounted and tested with high diligence. However, if there is still a reason for complaint, we will naturally try to give you entire satisfaction within the scope of our warranty. We will be at your disposal also after expiration of the warranty. In addition, you will also find all necessary instructions and spare part data for maintenance in this instruction manual. If you don't want to carry out the maintenance by yourself, our Guth Ventiltechnik GmbH - service team will naturally be at your disposal.

1.2 Marking of security instructions

Hints are available in the chapter "safety instructions" or directly before the respective operation instruction. The hints are highlighted with a danger symbol and a signal word. Texts beside these symbols have to be read and adhered to by all means. Please continue with the text and with the handling at the valve only afterwards.

Symbol	Signal word	Meaning
	DANGER	Imminent danger which will result severe personal injury or death.
	WARNING	Imminent danger which may result severe personal injury or death.
	CAUTION	Dangerous situation which may cause slight personal injury or material damages.
	NOTICE	An harmful situation which may result in damages of the product itself or of adjacent vicinity.
	INFORMATION	Marks application hints and other information which is particularly useful.

1.3 General designated use

The fitting is designed exclusively for the purposes described below. Using the fitting for purposes other than those mentioned is considered contrary to its designated use. Guth Ventiltechnik GmbH cannot be held liable for any damage resulting from such use. The risk of such misuse lies entirely with the user. The prerequisite for the reliable and safe operation of the fitting is proper transportation and storage as well as competent installation and assembly. Operating the fitting within the limits of its designated use also involves observing the operating, inspection and maintenance instructions.

1.4 Personnel

Personnel entrusted with the operation and maintenance of the tank safety system must have the suitable qualification to carry out their tasks. They must be informed about possible dangers and must understand and observe the safety instructions given in the relevant manual. Only allow qualified personnel to make electrical connections.

1.5 Modifications, spare parts, accessories

Unauthorized modifications, additions or conversions which affect the safety of the fitting are not permitted. Safety devices must not be bypassed, removed or made inactive. Only use original spare parts and accessories recommended by the manufacturer.

1.6 General instructions

The user is obliged to operate the fitting only when it is in good working order. In addition to the instructions given in the operating manual, please observe the relevant accident prevention regulations, generally accepted safety regulations, regulations effective in the country of installation, working and safety instructions effective in the user's plant.

2 Safety instructions

2.1 Intended use

This safety valve is used to prevent overpressure in tanks and vessels in plants of the food and drink industry, pharmaceutical and chemical industries as well as in biotechnology.

2.2 General notes



NOTICE - observe the operating instructions

To avoid danger and damage, the fitting must be used in accordance with the safety instructions and technical data contained in the operating instructions.



NOTICE

All data are in line with the current state of development. Subject to change as a result of technical progress.

2.3 General safety instructions



⚠ WARNING

Risk of injury by outflowing medium

Dismantling the valve or valve assemblies from the plant can cause injuries.

- Medias flowing through the leakage drain outlet are to be drained off without splashing into a discharge arrangement.
- Carry the disassembling only if when the plant has been rendered pressure-less and free of liquid and gas.



⚠ WARNING

Risk of injury by outflowing medium

With pressure greater than the set pressure the gaseous or liquid media will radial escape into the atmosphere via outlet drillings.

- It is necessary to install protection and drainage devices.



⚠ WARNING

ATEX - Guidelines

If the valve or the plant is operated in a potentially explosive atmosphere, the valid ATEX directive of the EC and the installation instructions in this operating manual must be observed.



⚠ CAUTION

Before starting the system, the entire pipeline system must be thoroughly cleaned.



⚠ CAUTION

Steps should be taken to ensure that no external forces are exerted on the fitting.

3 Delivery, transport and storage

3.1 Delivery

- Immediately after receipt check the delivery for completeness and transport damages.
- Remove the packaging from the product.
- Retain packaging material, or expose of according to local regulations.

3.2 Transport



CAUTION

Risk of injury and damage to the product

During the transport the generally acknowledged rules of technology, the national accident prevention regulations and company internal work and safety regulations must be observed.

3.3 Storage



NOTICE

Damage to the product due to improper storage!

Observe storage instructions

avoid a prolonged storage



INFORMATION



Recommendation for longer storage



We recommend regularly checking the product and the prevailing storage conditions during long storage times.

- To avoid damage to seals and bearings,
 - products up to DN 125 / OD 5 inch should be stored horizontally for maximum 6 months.
 - products larger than DN 125 / 5 inch, should be stored in the upright position with the actuator on top.
- Don't store any objects on the products.
- Protect the products for wetness, dust and dirt.
- The product should be stored in a dry and well ventilated room at a constant temperature (optimal indoor temperature: 25 C ±5 ; indoor humidity data 70% ±5%).
- Protect seals, bearings and plastic parts for UV light and ozone.

4 Specification

4.1 Valve types

safety valve		
Connection G (screw thread G1")		
6146	6148	6150
Basic	with lifting device	with flange for cleaning unit
		

safety valve		
Connection K/M (Liner/nut)		
6147	6149	6151
Basic	with lifting device	with flange for cleaning unit
		

5 Function and operation

5.1 Description of function

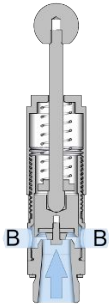

The safety valve is used to prevent inadmissible overpressure of gaseous media in tanks, containers and plant sections.

Generally, the set pressure is greater than the operating pressure. The valve opens against a spring force if the operating pressure increases to the set pressure.

With pressure increase analogous to the opening characteristic, the flow rate is dependent on the max. permissible operating pressure constantly discharged from the outlet drillings (B).

5.2 Commissioning, service and maintenance

5.2.1 Commissioning

5.2.1.1 Installation instructions



Fitting position

The safety valve must be installed vertically at connection "A" (see illustration right).

Functional check

After installation or after manual actuation of the valve disk, the closing function and the function in the operating state must be checked in accordance with the specified performance data.

5.2.1.2 General welding guidelines

Sealing elements integrated in weld components must generally be removed prior to welding. To prevent damage, welding should be undertaken by certified personnel (EN ISO 9606-1). Use the TIG (Tungsten Inert Gas) welding process.



CAUTION

Damage and injuries due to high temperature supply

To avoid a distortion of the components, all welding parts must be welded to stress-relieved. Allow all components to cool before assembling.



NOTICE

Damage due to impurities

Impurities can cause damage to the seals and seals area. Clean inside areas prior to assembly.

5.2.1.3 ATEX - Guidelines

For valves or plants/installations that are operated in the ATEX area, sufficient bonding (grounding) must be ensured (see valid ATEX Guidelines EG).

5.2.2 Service



RECOMMENDATION

Replacement of seals

To achieve optimal maintenance cycles, the following points must be observed!

- When replacement of seals, all product-contacting seals should be replaced.
- Only original spare parts may be installed.

Maintenance interval

The maintenance intervals depend on the operating conditions "temperature, temperature-intervals, medium, cleaning medium, pressure and opening frequency". We recommend replacing the seals 2-year cycle. The user, however, should establish appropriate maintenance intervals according to the condition of the seals.

Lubricant recommendation

	EPDM; HNBR; NBR; FKM; k-flex	-	Klüber Paraliq GTE703*
	Silicone	-	Klüber Sintheso pro AA2*
	Thread	-	Interflon Food*
*) It is only permitted to use approved lubricants, if the respective fitting is used for the production of food or drink. Please observe the relevant safety data sheets of the manufacturers of lubricants.			

5.2.3 Cleaning

Cleaning

The optimum cleaning is carried out with the tank or pipe cleaning.

6 Technical data

6.1 Safety valves

Model:	safety valve spring close for gaseous and vaporous media	
Valve size:	DN20	
Connection:	Male (G) DIN 11851 Liner/nut (K/M) DIN 11851	
Operating temperature:	-10°C bis +95°C (gas, steam)	
Sterilization temperature:	EPDM	+130°C (SIP 30 min)
	FKM	+90°C (SIP 30 min)
Leak rate:	A (DIN EN 12266-1)	
Pressure range:	<u>Design: Seal</u> 0,5 - 0,9 bar 0,8 - 1,9 bar 1,1 - 2,7 bar 2,5 - 8,0 bar	<u>Design: O-Ring</u> 0,5 - 0,9 bar 4,0 - 10 bar
Discharge coefficient	0.39	0.1
in product contact:	Stainless steel:	1.4301 / AISI 304 1.4404 / AISI316L
	Surfaces:	Ra < 0,8µm e-polished
	Sealing material:	EPDM (FDA) FKM (FDA)

6.2 Identification

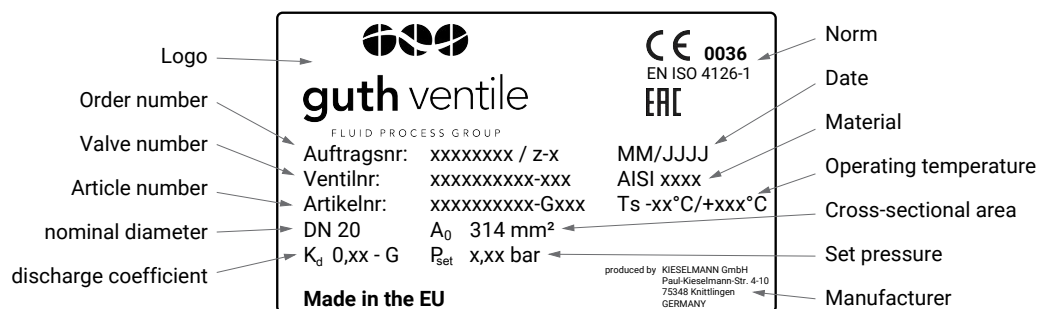

7 Disassembly and assembly

7.1 Disassembly



NOTICE

All screw connections have right-handed threads.

Disassembly

- Unscrew the spherical button.
 - Type 6148, 6149: Unscrew the lifting nut.
- Unscrew spring case (the pressure spring is released).
- Unscrew the valve housing out of the tightly seat.
- Remove the valve shaft, pressure spring, spring disc and distance.

Design: o-ring

- Remove O-ring out of the valve disc.

NOTICE!

- Puncture the O-ring with a needle and remove them carefully from the groove of piston.

Design: seal disc

- Unscrew the screw from the valve plate. Remove the washer and seal disc.

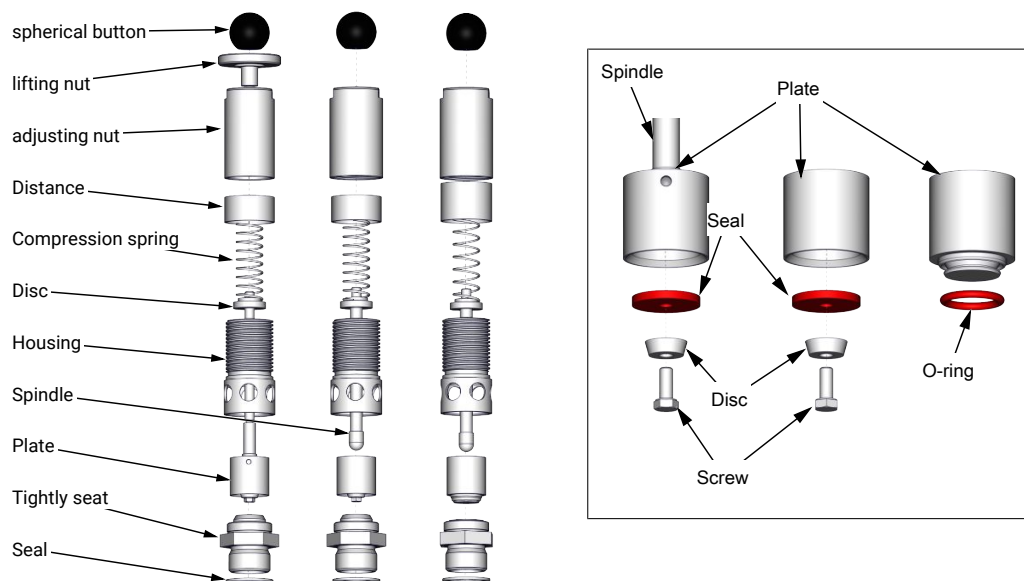

7.2 Assembly



⚠ CAUTION

Deviating set pressure

If not assembled properly, the set pressure may deviating.

- The distance is adjusted valve-specific.
 - Distances may not be exchanged or swapped.
 - The adjusting nut must be screwed onto the fixed stop against the distance.

- Before installation, thoroughly clean and slightly lubricate mounting areas and running surfaces.
- Assemble in reverse order.



NOTICE

Alternately press and roll the O-rings into the groove with round body.

Performance test

- Check the function according to the specified performance data in the operating state.

8 Drawings and dimensions

8.1 Design: seal disc

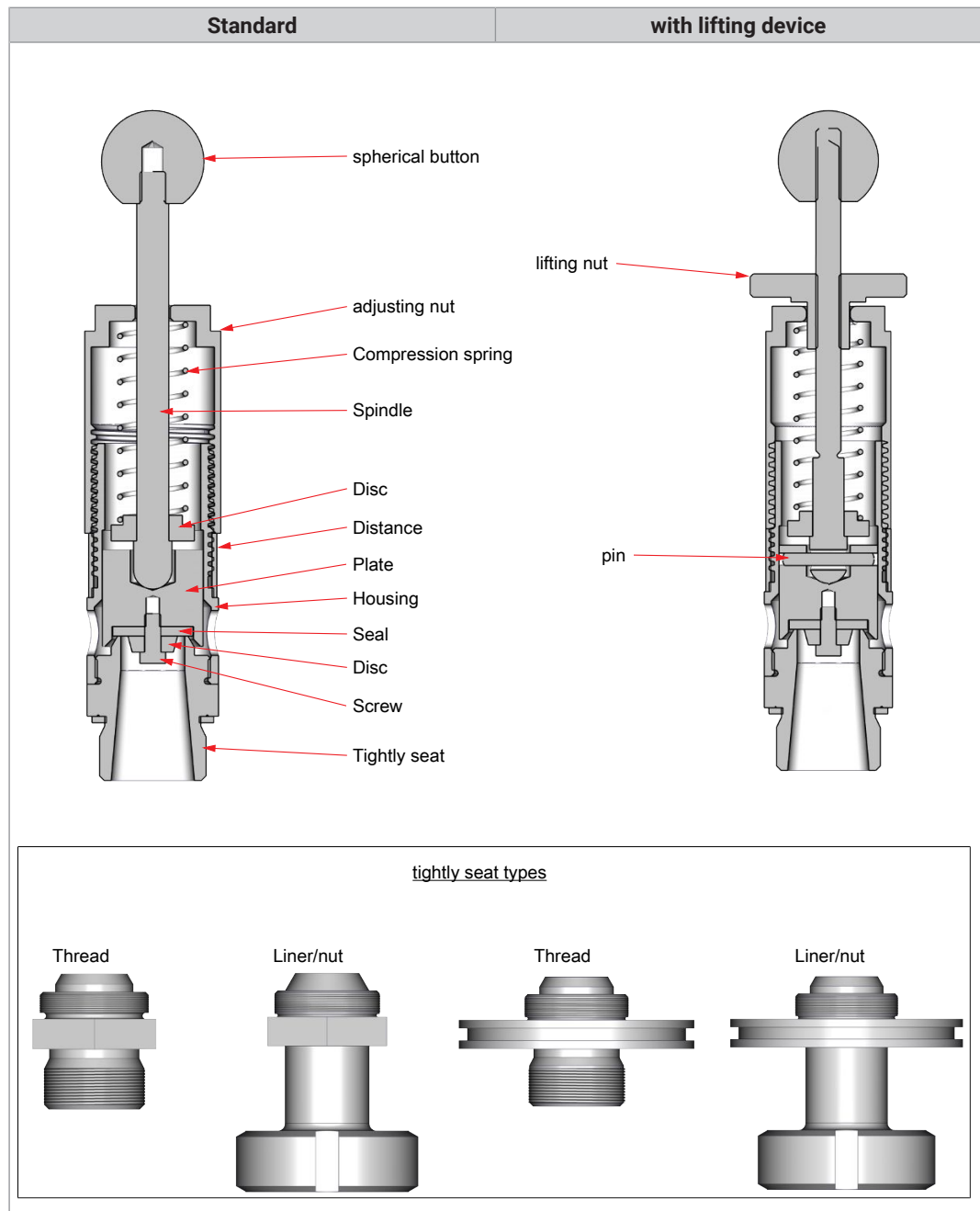

8.2 Design: O-Ring

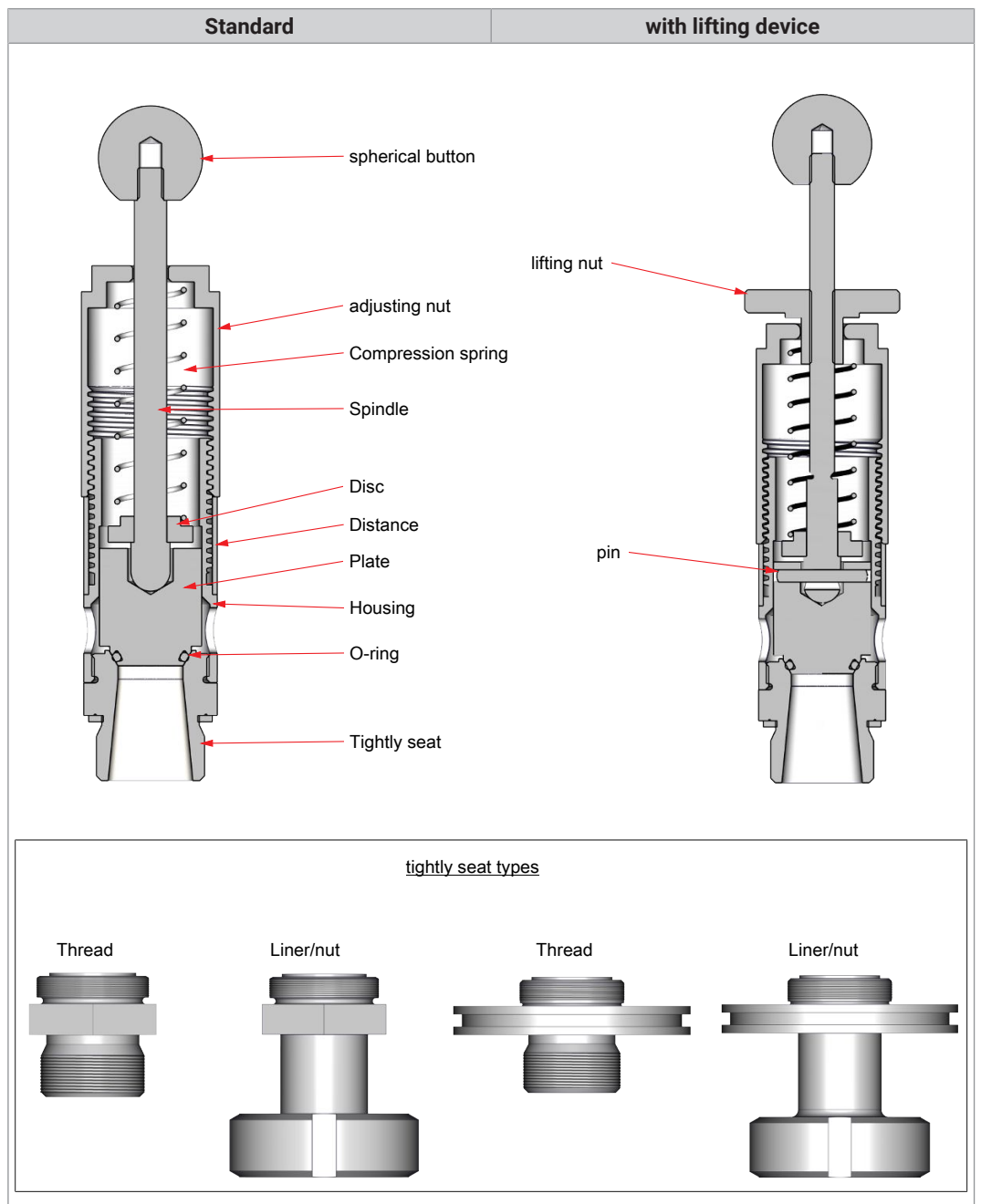

8.3 Dimensions

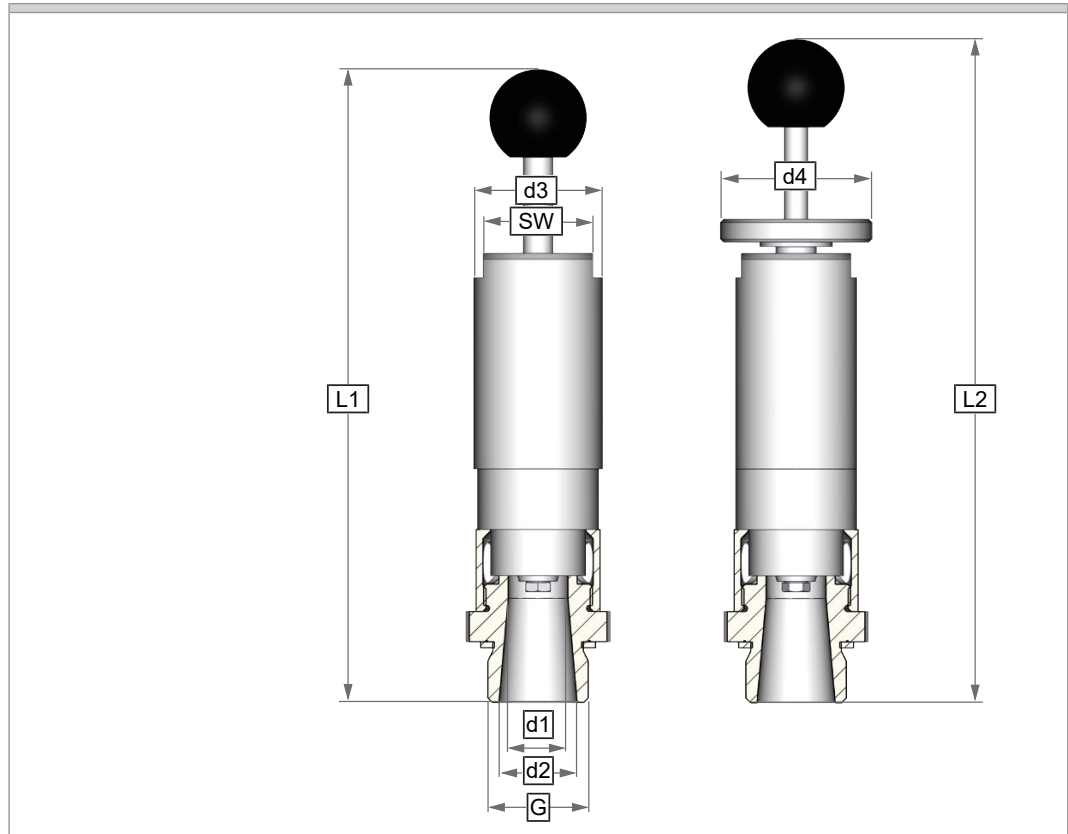

DN	G	d1	d2	d3	d4	L1	L2	SW
20	1"	Ø 20	Ø 26	Ø 42.5	Ø 50	~ 208	~ 230	36

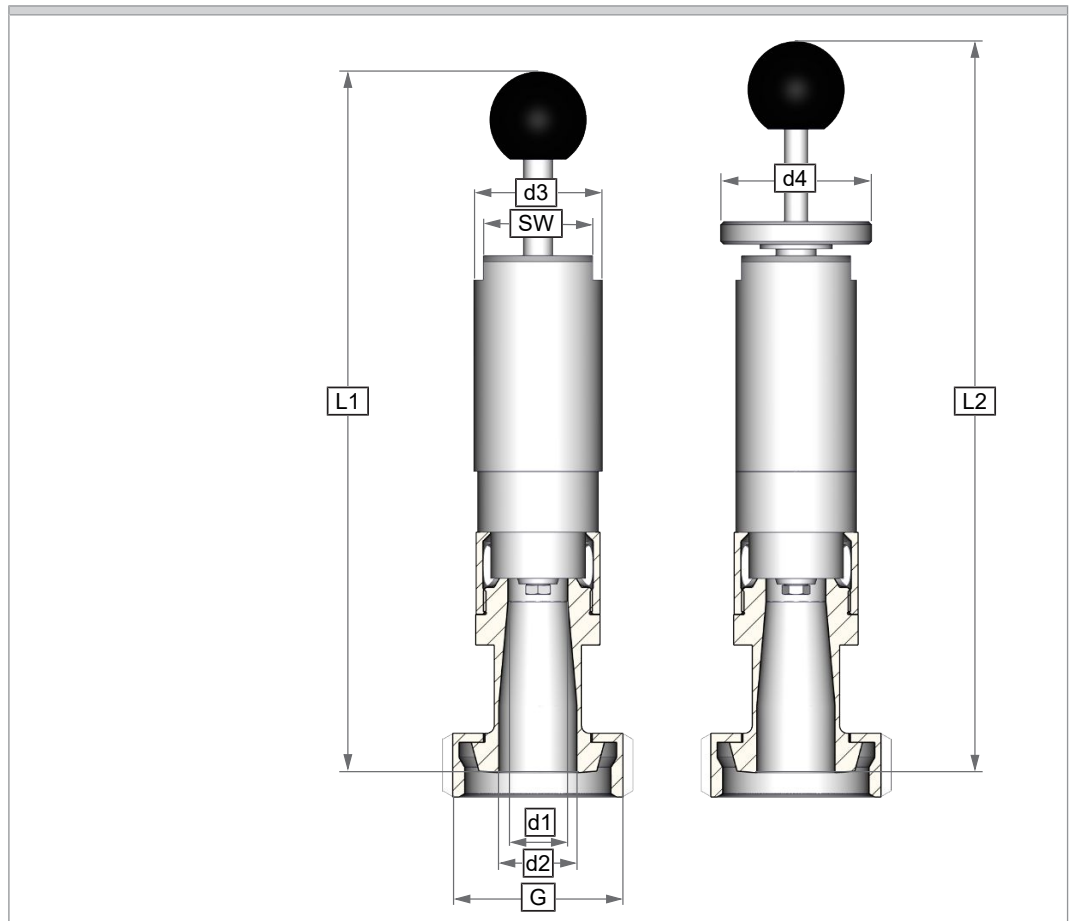

DN	G	d1	d2	d3	d4	L1	L2	SW
20 / 25	Rd52x1/6	Ø 20	Ø 26	Ø 42.5	Ø 50	~ 230	~ 244	36
20 / 32	Rd58x1/6	Ø 20	Ø 26	Ø 42.5	Ø 50	~ 234	~ 246	36
20 / 40	Rd65x1/6	Ø 20	Ø 26	Ø 42.5	Ø 50	~ 234	~ 246	36
20 / 50	Rd78x1/6	Ø 20	Ø 26	Ø 42.5	Ø 50	~ 235	~ 248	36
20 / 65	Rd95x1/6	Ø 20	Ø 26	Ø 42.5	Ø 50	~ 237	~ 250	36

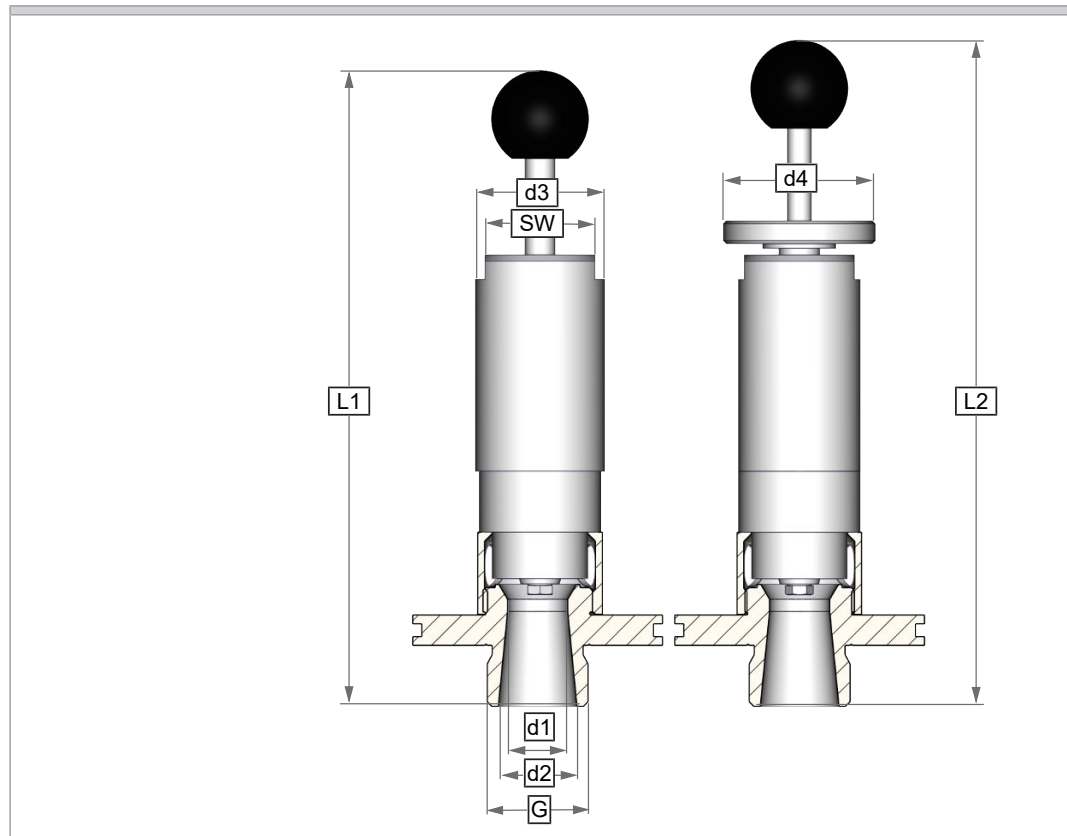

DN	G	d1	d2	d3	d4	L1	L2	SW
20 / 25	1"	Ø 20	Ø 26	Ø 42.5	Ø 50	~ 208	~ 230	36

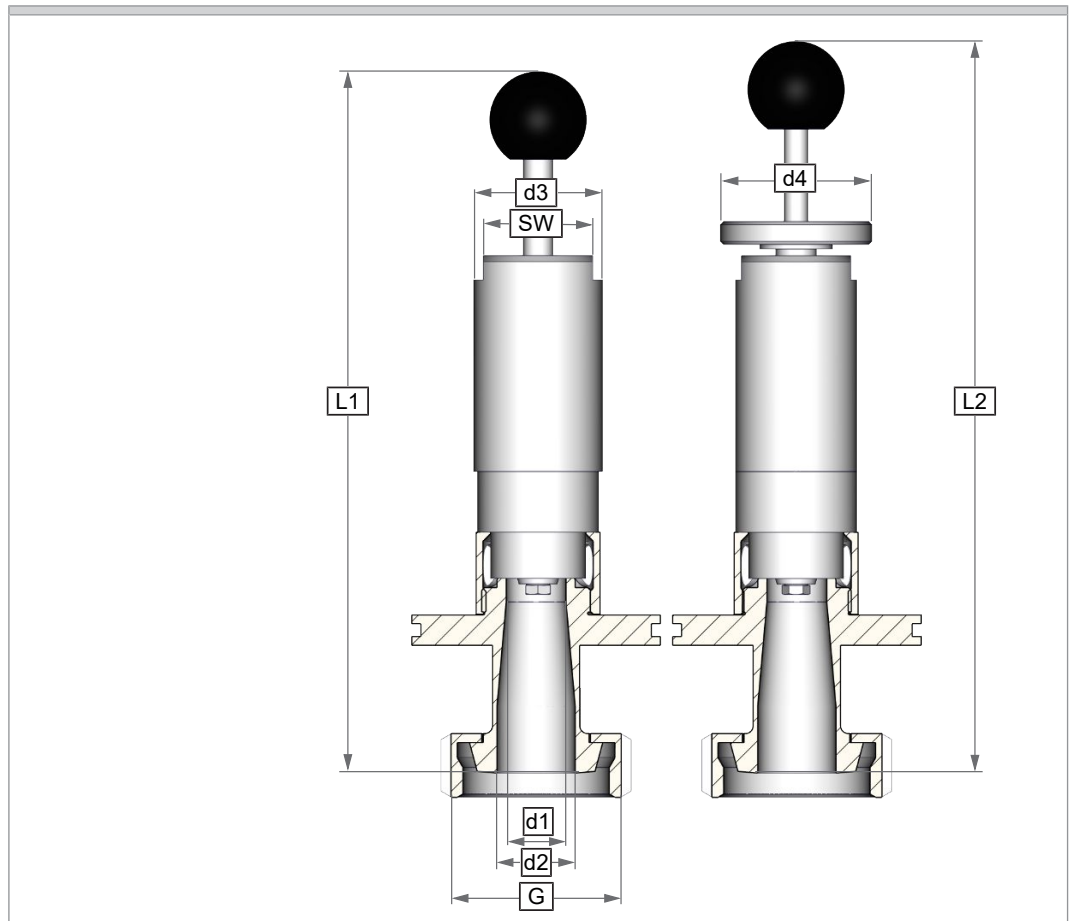

DN	G	d1	d2	d3	d4	L1	L2	SW
20 / 25	Rd52x1/6	Ø 20	Ø 26	Ø 42.5	Ø 50	~ 230	~ 244	36
20 / 32	Rd58x1/6	Ø 20	Ø 26	Ø 42.5	Ø 50	~ 234	~ 246	36
20 / 40	Rd65x1/6	Ø 20	Ø 26	Ø 42.5	Ø 50	~ 234	~ 246	36
20 / 50	Rd78x1/6	Ø 20	Ø 26	Ø 42.5	Ø 50	~ 235	~ 248	36
20 / 65	Rd95x1/6	Ø 20	Ø 26	Ø 42.5	Ø 50	~ 237	~ 250	36

9 Characteristic curves

9.1 Opening & closing characteristics

Opening and closing characteristics

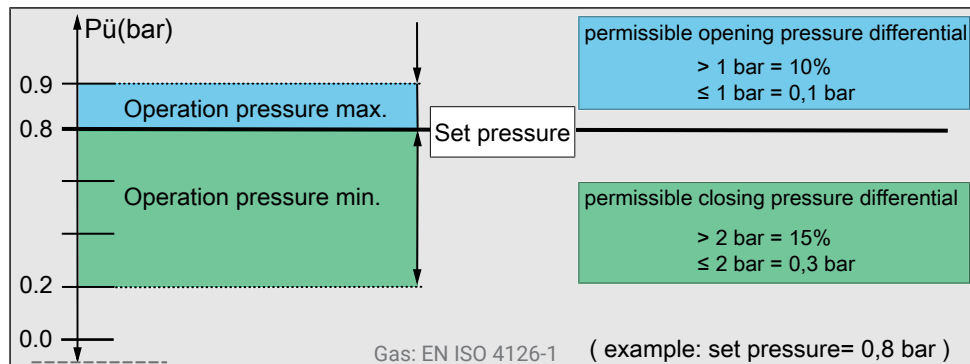
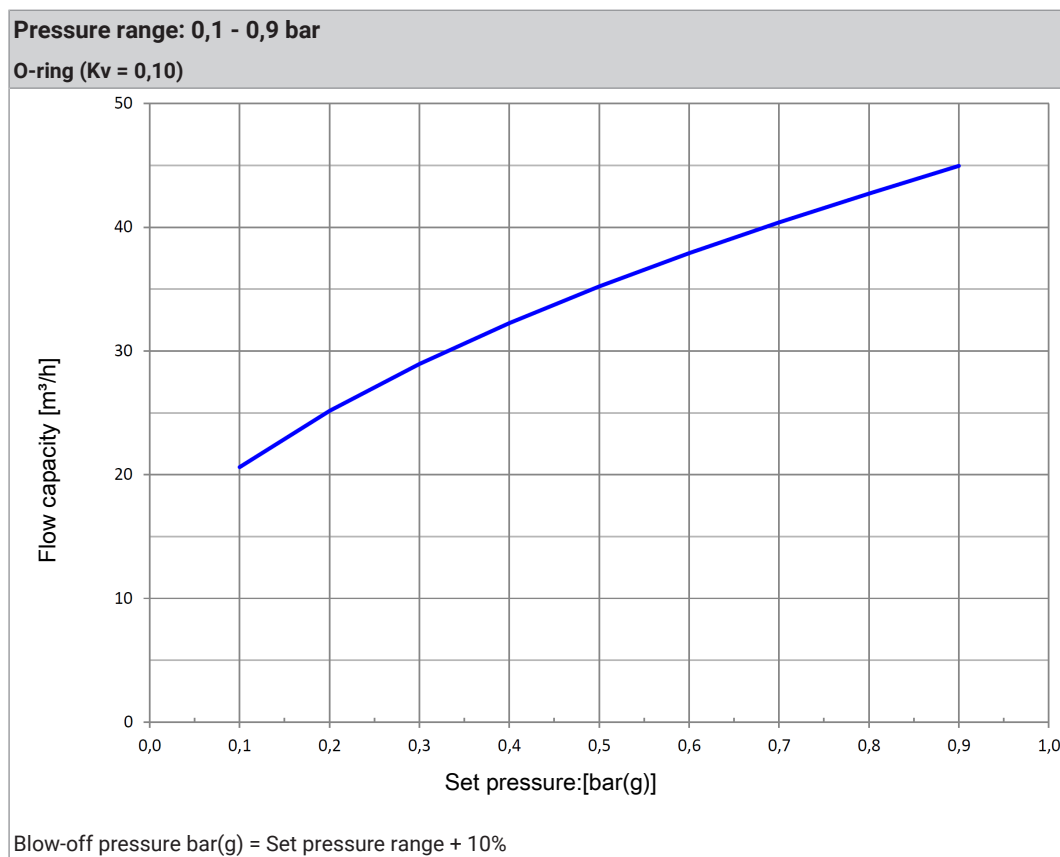
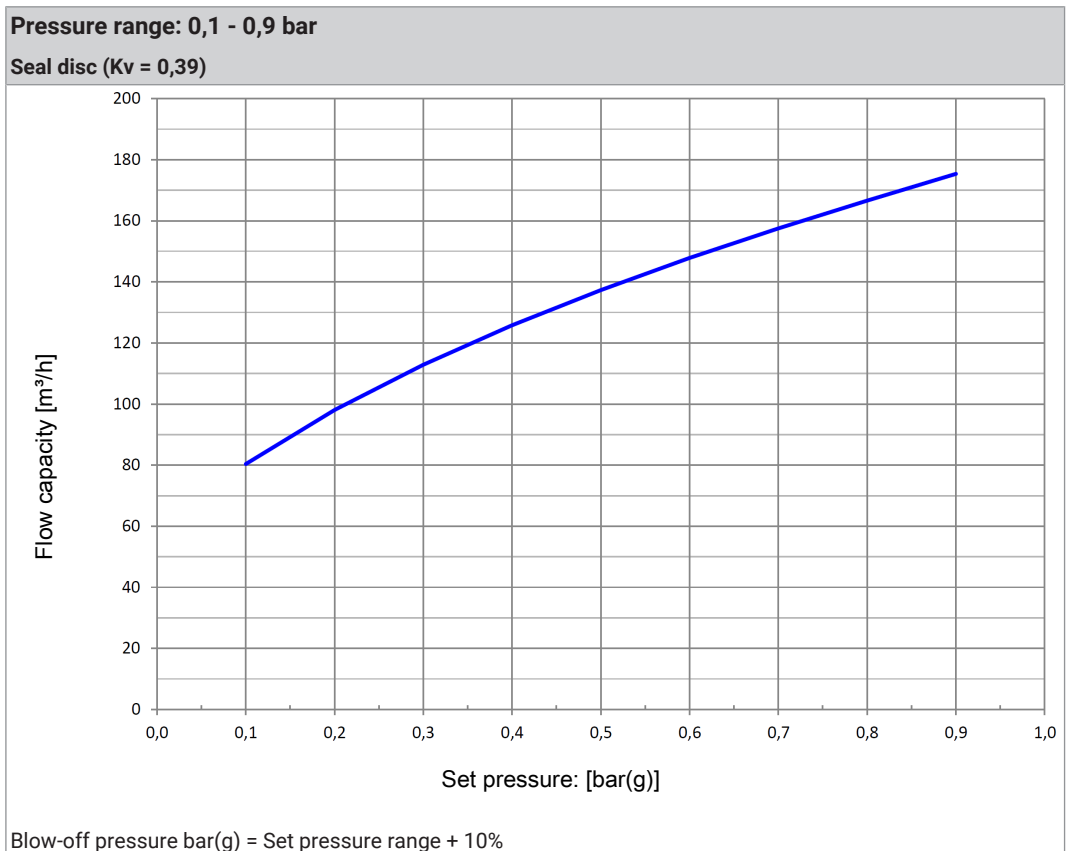
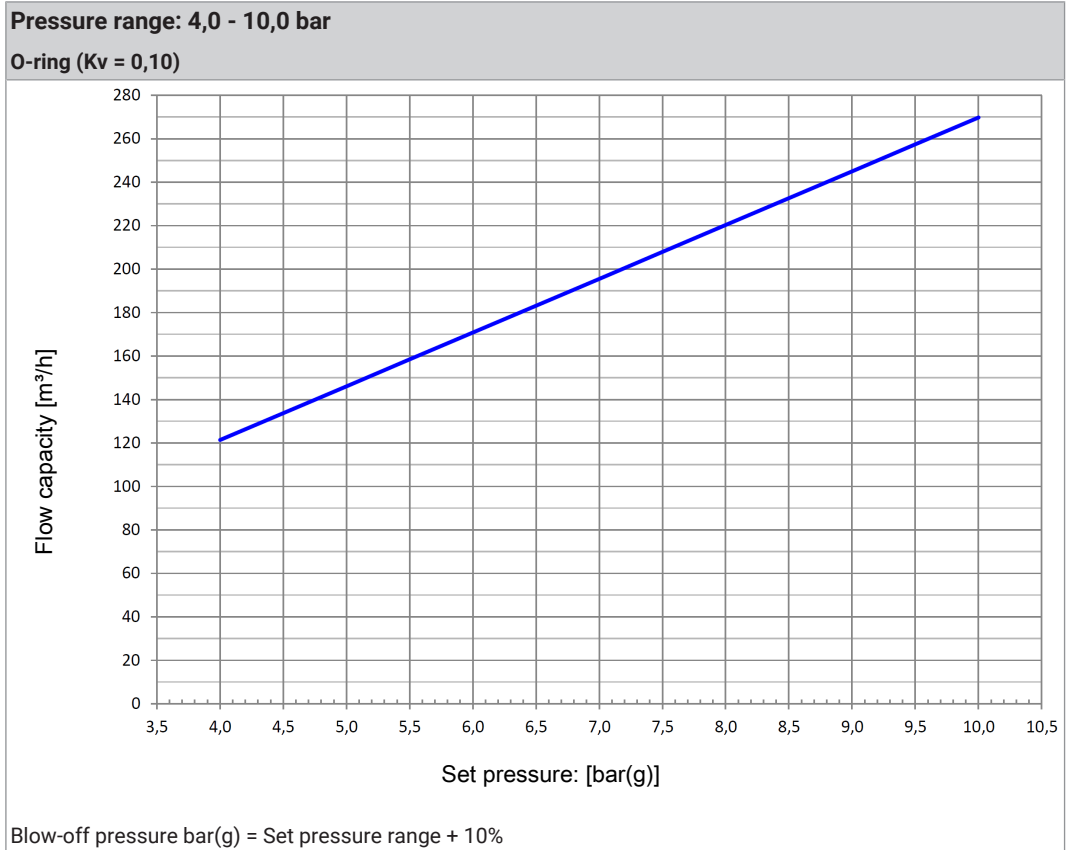
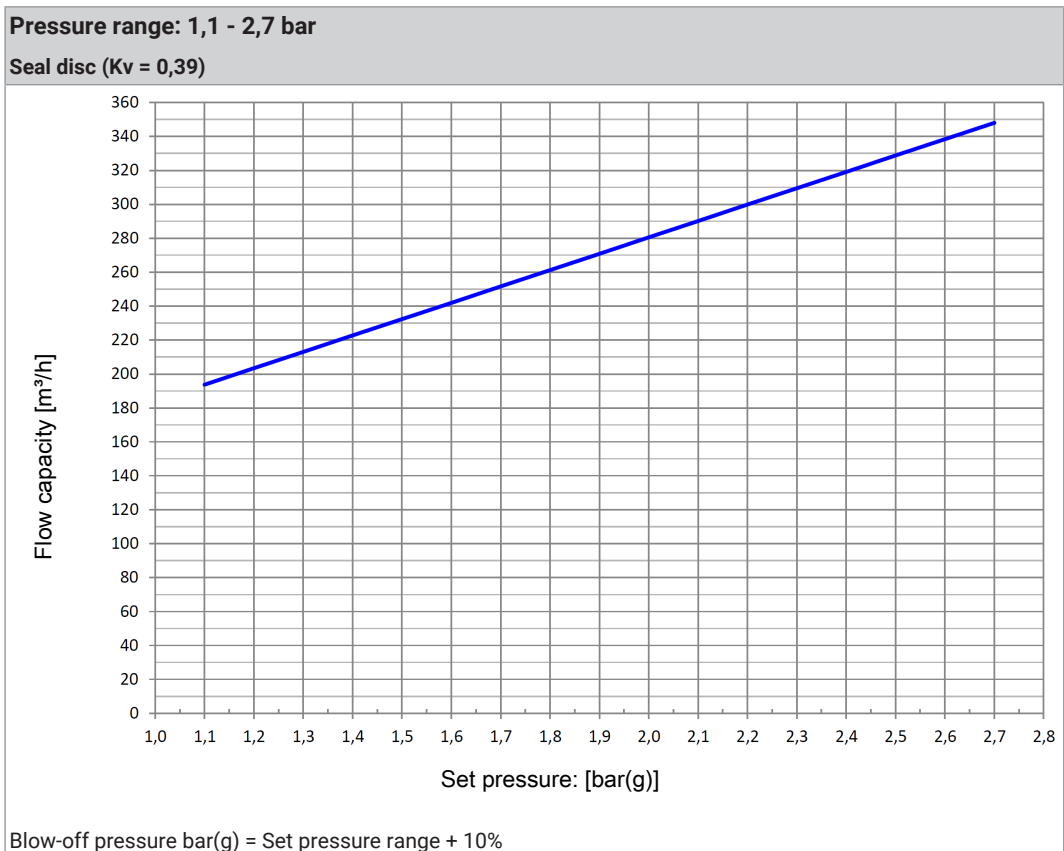
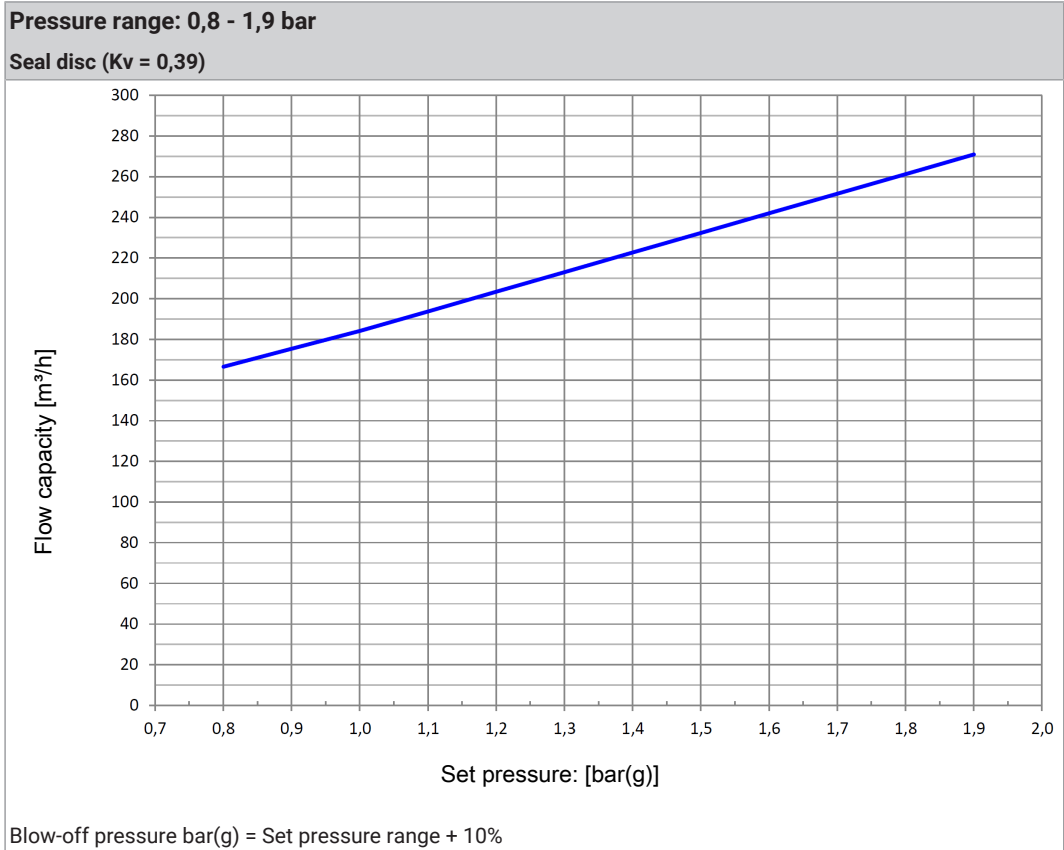

Illustration 1

9.2 Blow-off performance chart







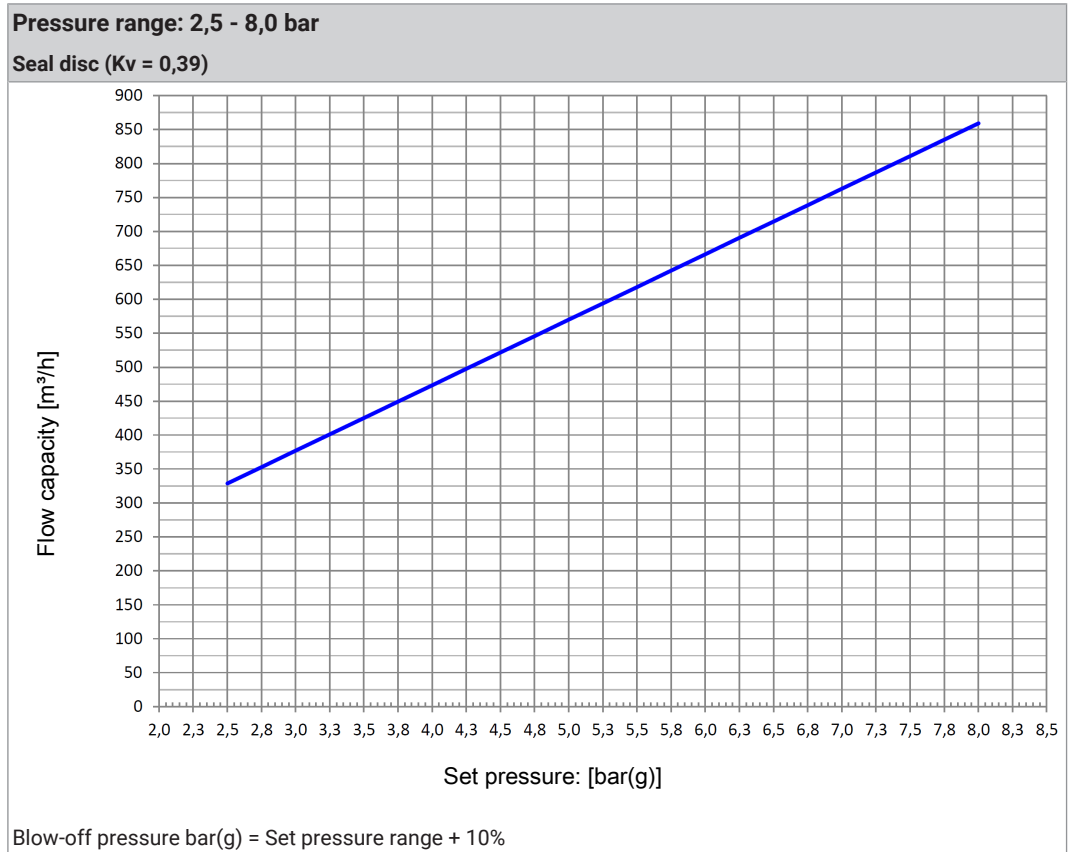

10 Appendix

See also

EE_Gvt_MRL2006-42-EG [▶ 24]

10.1 EE_Gvt_MRL2006-42-EG



CE Declaration of incorporation

Translation of the original

Manufacturer / authorised representative:	Guth Ventiltechnik GmbH Horstring 16 76829 Landau Germany
Authorised representative, for compiling technical documents:	Achim Kauselmann Documentation / Development KIESELMANN GmbH

Product

pneum. Lift actuators
pneum. Rotary actuators
Ball valves
Butterfly valves
Single seat valves
Flow control valves
Throttle valve
Overflow valve
Double seat valve
Bellows valves
Sampling valves
Two way valves
Tankdome fitting
Safety valve

Function

Stroke movement
Rotary movement
Media cutoff
Media cutoff
Media cutoff
Control of liquefied media
Control of liquefied media
Definition of fluid pressure
Media separation
Sampling of liquids
Sampling of liquids
Media cutoff
Prevention of overpressure and vacuum, Tank cleaning
Prevention of overpressure

The manufacturer hereby states that the above product is considered as an incomplete machine in the sense defined in the Directive 2006/42/EC on Machinery. The above product is exclusively intended to be installed into a machine or an incomplete machine. The said product does not yet conform to all the relevant requirements defined in the Directive on Machinery referred to above for this reason.

The specific technical documents listed in Appendix VII, Part B, have been prepared. The Authorized Agent empowered to compile technical documents may submit the relevant documents if such a request has been properly justified.

Commissioning of an incomplete machine must not only be carried out if it has been determined that the respective machine into which the incomplete machine is to be installed conforms to the regulations set out in the Directive on Machinery referred to above.

The above product conforms to the requirements of the directives and harmonized standards specified below:

- Directive 2014/68/EU
- DIN EN ISO 12100 Safety of machinery

Landau, 01.07.2016

Jens Klene
General Manager