

Cylindrical sight glass

ak / 21/02/2024

Type: 7007xxx000-xxx

G-G, NBR

Glass cylinder: Borosilicate

Translation of the original

Safety instructions**Intended use**

The fitting to be built into pipe conduits to allow the inspection of liquids.

General notes**NOTICE - observe the operating instructions**

To avoid danger and damage, the fitting must be used in accordance with the safety instructions and technical data contained in the operating instructions.

**NOTICE**

All data are in line with the current state of development. Subject to change as a result of technical progress.

General safety instructions**WARNING****Risk of injury by outflowing medium**

Dismantling the valve or valve assemblies from the plant can cause injuries.

- Media flowing through the leakage drain outlet are to be drained off without splashing into a discharge arrangement.
- Carry the disassembling only if when the plant has been rendered pressure-less and free of liquid and gas.

**WARNING****Danger of injury due exceeding the operating pressure**

If the maximum permissible working pressure is exceeded, accident hazard due to bursting of the glass cylinder or discharge of liquids into the atmosphere is possible.

- In order to avoid excess pressure install over-pressure protections.
- The fitting position has to be chosen in such a way as to exclude danger of accident. In order to prevent accident hazards, provide appropriate protective devices.

Function and operation**Installation instructions**

External forces due to the installation must always be avoided.

Fitting position

- The installation position is without importance.

Cleaning

Optimum cleaning is achieved with pipeline cleaning.

Technical data

Model	Sight glass	
Size	DN10 - DN150	
Connection type	Male part DIN11851	
Temperature		
Ambient	(air)	+4°C / +45°C
Operation	(medium dependent)	+0 °C / +90 °C
Sterilization	(SIP 30 min)	NBR +100 °C
Pressure range		
Nominal pressure	DN10 - DN20	= PN 10
[bar]	DN25 - DN50	= PN 8
	DN 65	= PN 6
	DN 80	= PN 5
	DN100 - DN150	= PN 4
Materials in product contact		
stainless steel	1.4301 / AISI 304	
	1.4404 / AISI 316L	
Surface	Ra ≤ 0,8µm	
Seal	NBR	
Glass cylinder	Borosilicate	

Cylindrical sight glass

Type: 7007xxx000-xxx

G-G, NBR

Glass cylinder: Borosilicate

Translation of the original

Disassembly and assembly

Disassembly

- Determine adjustment dimension "A" (see Fig.1).
- Unscrew hexagon nut (6) on one side.
- Remove flange (1) seal (2) and glass cylinder (3) axially.

Welding preparations

- Position the flange (1) in the threaded bolt (4) to the end stop against the hexagon nut (5) and tighten with a hexagonal nut (6).
- Check determined size "A". If required, adjust via the hexagonal nut (5).
- Make sure the flanges are planar parallel.

Assembly

- Install seal (2) and glass cylinder (3) in the center.
- Position the flange (1) in the threaded bolt (4) to the end stop against the hexagon nut (5) and tighten with a hexagonal nut (6).
- Make sure the flanges are planar parallel.
- Screw the intended detachable connection.

Functional check

- Check the fitting for leaks.
- If the fitting leaks, loosen the hexagonal nut (5) and tighten evenly the hexagonal nut (6). Make sure the flanges are planar parallel. Lock with hexagonal nut (5).

Lubricant recommendation

i	EPDM; HNBR; NBR; FKM; k-flex	- Klüber Paraliq GTE703*
	Silicone	- Klüber Sintheso pro AA2*
	Thread	- Interflon Food*
	*) It is only permitted to use approved lubricants, if the respective fitting is used for the production of food or drink. Please observe the relevant safety data sheets of the manufacturers of lubricants.	

Drawings and dimensions

DN	L1	L2	A	D1	D2	D3	LK
10	65	135	~ 61	Ø 13x1,5	Ø 44	Rd28x1/8	Ø 32
15	65	135	~ 61	Ø 19x1,5	Ø 49	Rd34x1/8	Ø 37
20	75	149	~ 71	Ø 23x1,5	Ø 54	Rd44x1/6	Ø 43
25	75	149	~ 69	Ø 29x1,5	Ø 80	Rd52x1/6	Ø 65
32	75	152	~ 69	Ø 35x1,5	Ø 86	Rd58x1/6	Ø 71
40	85	163	~ 79	Ø 41x1,5	Ø 92	Rd65x1/6	Ø 77
50	85	169	~ 79	Ø 53x1,5	Ø 108	Rd78x1/6	Ø 92
65	85	170	~ 77	Ø 70x2	Ø 130	Rd95x1/6	Ø 110
80	85	189	~ 77	Ø 85x2	Ø 146	Rd110x1/4	Ø 126
100	100	209	~ 92	Ø 104x2	Ø 166	Rd130x1/4	Ø 146
125	120	222	~ 112	Ø 129x2	Ø 205	Rd160x1/4	Ø 180
150	150	270	~ 140	Ø 154x2	Ø 240	Rd190x1/4	Ø 215

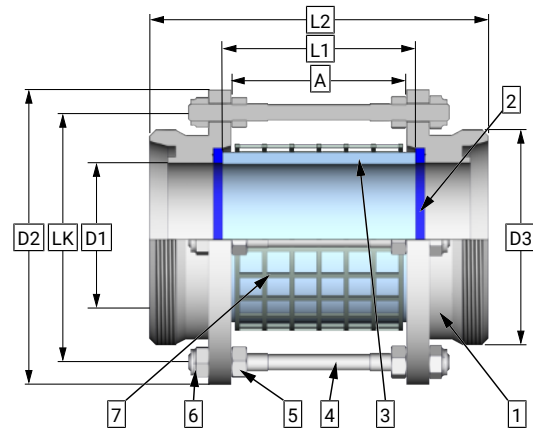

1 Flange	2 Seal
3 Glass cylinder	4 Threaded rod
5 Hexagon nut	6 Hexagon nut
7 Protecting cover	A Adjustment dimension
D1 Diameter 1	D2 Diameter 2
D3 Diameter 3	L1 Dimension glass cylinder
L2 Total length	LK Bolt circle

All data are in line with the current state of development. Subject to change as a result of technical progress.

Wearing parts

Article number	Pos. 1 Male flange (2x)	Pos. 2 Seal (2x)	Pos. 3 Glass cylinder (1x)	Pos. 4 Threaded rod	Pos. 5 Hexagon nut DIN934	Pos. 6 Hexagon nut DIN985	Pos. 7 Protecting cover
	AISI 304 / 316L	NBR	Borosilicate	AISI 304	AISI 304	AISI 304	AISI 304
7007010000-021	7007 010 001-020	2354 020 010-067	7012 010 000-073	7006 015 002-020 M6x96 (3x)	8107 006 000-020 M6 (6x)	8115 006 000-020 M6 (6x)	7011 010 000-021
7007010000-041	7007 010 001-040						
7007015000-021	7007 015 001-020	2354 025 016-067	7012 015 000-073	7006 015 002-020 M6x96 (3x)	8107 006 000-020 M6 (6x)	8115 006 000-020 M6 (6x)	7011 015 000-021
7007015000-041	7007 015 001-040						
7007020000-021	7007 020 001-020	2354 031 020-067	7012 020 000-073	7006 020 002-020 M6x106 (3x)	8107 006 000-020 M6 (6x)	8115 006 000-020 M6 (6x)	7011 020 000-021
7007020000-041	7007 020 001-040						
7007025000-021	7007 025 001-020	2355 036 026-067	7012 025 000-073	7006 032 002-020 M8x105 (4x)	8107 008 000-020 M8 (8x)	8115 008 000-020 M8 (8x)	7011 025 000-021
7007025000-041	7007 025 001-040						
7007032000-021	7007 032 001-020	2355 042 032-067	7012 032 000-073	7006 032 002-020 M8x105 (4x)	8107 008 000-020 M8 (8x)	8115 008 000-020 M8 (8x)	7011 032 000-021
7007032000-041	7007 032 001-040						
7007040000-021	7007 040 001-020	2355 052 038-067	7012 040 000-073	7006 065 002-020 M8x115 (4x)	8107 008 000-020 M8 (8x)	8115 008 000-020 M8 (8x)	7011 040 000-021
7007040000-041	7007 040 001-040						
7007050000-021	7007 050 001-020	2355 064 050-067	7012 050 000-073	7006 065 002-020 M8x115 (4x)	8107 008 000-020 M8 (8x)	8115 008 000-020 M8 (8x)	7011 050 000-021
7007050000-041	7007 050 001-040						
7007065000-021	7007 065 001-020	2355 079 066-067	7012 065 000-073	7006 065 002-020 M8x115 (4x)	8107 008 000-020 M8 (8x)	8115 008 000-020 M8 (8x)	7011 065 000-021
7007065000-041	7007 065 001-040						
7007080000-021	7007 080 001-020	2355 094 081-067	7012 080 000-073	7006 080 002-020 M10x123(4x)	8107 010 000-020 M10 (8x)	8115 010 000-020 M10 (8x)	7011 080 000-021
7007080000-041	7007 080 001-040						
7007100000-021	7006 100 001-020	2355 114 100-067	7012 100 000-073	7006 100 002-020 M10x138(4x)	8107 010 000-020 M10 (8x)	8115 010 000-020 M10 (8x)	7011 100 000-021
7007100000-041	7006 100 001-040						
7007125000-021	7006 125 001-020	2355 144 125-067	7012 125 000-073	7006 125 002-020 M10x163 (4x)	8107 010 000-020 M10 (8x)	8115 010 000-020 M10 (8x)	7011 125 000-021
7007125000-041	7006 125 001-040						
7007150000-021	7006 150 001-020	2355 169 150-067	7012 150 000-073	7006 150 002-020 M12x202 (6x)	8107 012 000-020 M12 (12x)	8115 012 000-020 M12 (12x)	7011 150 000-021
7007150000-041	7006 150 001-040						