

## Cylindrical sight glass

ak / 21/02/2024

Type: 7006xxx000-xxx

S-S, NBR

Glass cylinder: Borosilicate

Translation of the original

## Safety instructions

## Intended use

The fitting to be built into pipe conduits to allow the inspection of liquids.

## General notes

**NOTICE - observe the operating instructions**

To avoid danger and damage, the fitting must be used in accordance with the safety instructions and technical data contained in the operating instructions.

**NOTICE**

All data are in line with the current state of development. Subject to change as a result of technical progress.

## General safety instructions

**WARNING****Risk of injury by outflowing medium**

Dismantling the valve or valve assemblies from the plant can cause injuries.

- Media flowing through the leakage drain outlet are to be drained off without splashing into a discharge arrangement.
- Carry the disassembling only if when the plant has been rendered pressure-less and free of liquid and gas.

**WARNING****Danger of injury due exceeding the operating pressure**

If the maximum permissible working pressure is exceeded, accident hazard due to bursting of the glass cylinder or discharge of liquids into the atmosphere is possible.

- In order to avoid excess pressure install over-pressure protections.
- The fitting position has to be chosen in such a way as to exclude danger of accident. In order to prevent accident hazards, provide appropriate protective devices.

## Function and operation

## Installation instructions

External forces due to the installation must always be avoided.

## Fitting position

- The installation position is without importance.

## Cleaning

Optimum cleaning is achieved with pipeline cleaning.

## Technical data

Model	Sight glass	
Size	DN10 - DN150	
Connection type	Weld-on end DIN EN 10357	
Temperature		
Ambient	(air)	+4°C / +45°C
Operation	(medium dependent)	+0 °C / +90 °C
Sterilization	(SIP 30 min)	NBR +100 °C
Pressure range		
Nominal pressure	DN10 - DN20	= PN 10
[bar]	DN25 - DN50	= PN 8
	DN 65	= PN 6
	DN 80	= PN 5
	DN100 - DN150	= PN 4
Materials in product contact		
stainless steel	1.4301 / AISI 304	
	1.4404 / AISI 316L	
Surface	Ra ≤ 0,8µm	
Seal	NBR	
Glass cylinder	Borosilicate	

Cylindrical sight glass

Type: 7006xxx000-xxx

S-S, NBR

Glass cylinder: Borosilicate

Translation of the original

Disassembly and assembly

Disassembly

- Determine adjustment dimension "A" (see Fig.1).
- Unscrew hexagon nut (6) on one side.
- Remove flange (1) seal (2) and glass cylinder (3) axially.

Welding preparations

- Position the flange (1) in the threaded bolt (4) to the end stop against the hexagon nut (5) and tighten with a hexagonal nut (6).
- Check determined size "A". If required, adjust via the hexagonal nut (5).
- Make sure the flanges are planar parallel.

Assembly

- Install seal (2) and glass cylinder (3) in the center.
- Position the flange (1) in the threaded bolt (4) to the end stop against the hexagon nut (5) and tighten with a hexagonal nut (6).
- Make sure the flanges are planar parallel.
- Screw the intended detachable connection.

Functional check

- Check the fitting for leaks.
- If the fitting leaks, loosen the hexagonal nut (5) and tighten evenly the hexagonal nut (6). Make sure the flanges are planar parallel. Lock with hexagonal nut (5).

Lubricant recommendation

<b>i</b>	EPDM; HNBR; NBR; FKM; k-flex	- Klüber Paraliq GTE703*
	Silicone	- Klüber Sintheso pro AA2*
	Thread	- Interflon Food*
	*) It is only permitted to use approved lubricants, if the respective fitting is used for the production of food or drink. Please observe the relevant safety data sheets of the manufacturers of lubricants.	

Drawings and dimensions

DN	L1	L2	A	D1	D2	LK
10	65	97	~ 61	Ø 13x1,5	Ø 44	Ø 32
15	65	97	~ 61	Ø 19x1,5	Ø 49	Ø 37
20	75	107	~ 71	Ø 23x1,5	Ø 54	Ø 43
25	75	117	~ 69	Ø 29x1,5	Ø 80	Ø 65
32	75	117	~ 69	Ø 35x1,5	Ø 86	Ø 71
40	85	127	~ 79	Ø 41x1,5	Ø 92	Ø 77
50	85	131	~ 79	Ø 53x1,5	Ø 108	Ø 92
65	85	127	~ 77	Ø 70x2	Ø 130	Ø 110
80	85	143	~ 77	Ø 85x2	Ø 146	Ø 126
100	100	154	~ 92	Ø 104x2	Ø 166	Ø 146
125	120	188	~ 112	Ø 129x2	Ø 205	Ø 180
150	150	232	~ 140	Ø 154x2	Ø 240	Ø 215

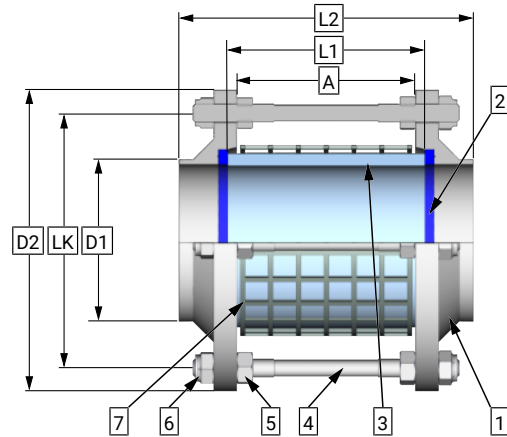

1 Flange	2 Seal
3 Glass cylinder	4 Threaded rod
5 Hexagon nut	6 Hexagon nut
7 Protecting cover	A Adjustment dimension
L1 Dimension glass cylinder	L2 Total length
D1 Diameter 1	D2 Diameter 2
LK Bolt circle	

All data are in line with the current state of development. Subject to change as a result of technical progress.

**Wearing parts**

Article number	Pos. 1 Welding flange (2x)	Pos. 2 Seal (2x)	Pos. 3 Glass cylinder (1x)	Pos. 4 Threaded rod	Pos. 5 Hexagon nut DIN934	Pos. 6 Hexagon nut DIN985	Pos. 7 Protecting cover
	AISI 304 / 316L	NBR	Borosilicate	AISI 304	AISI 304	AISI 304	AISI 304
7006010000-021	7006 010 001-020	2354 020 010-067	7012 010 000-073	7006 015 002-020	8107 006 000-020	8115 006 000-020	7011 010 000-021
7006010000-041	7006 010 001-040			7006 015 002-020	8107 006 000-020	8115 006 000-020	7011 015 000-021
7006015000-021	7006 015 001-020	2354 025 016-067	7012 015 000-073	7006 015 002-020	8107 006 000-020	8115 006 000-020	7011 020 000-021
7006015000-041	7006 015 001-040			7006 020 002-020	8107 006 000-020	8115 006 000-020	7011 025 000-021
7006020000-021	7006 020 001-020	2354 031 020-067	7012 020 000-073	7006 020 002-020	8107 008 000-020	8115 008 000-020	7011 032 000-021
7006020000-041	7006 020 001-040			7006 032 002-020	8107 008 000-020	8115 008 000-020	7011 040 000-021
7006025000-021	7006 025 001-020	2355 036 026-067	7012 025 000-073	7006 032 002-020	8107 008 000-020	8115 008 000-020	7011 050 000-021
7006025000-041	7006 025 001-040			7006 065 002-020	8107 008 000-020	8115 008 000-020	7011 065 000-021
7006032000-021	7006 032 001-020	2355 042 032-067	7012 032 000-073	7006 032 002-020	8107 010 000-020	8115 010 000-020	7011 080 000-021
7006032000-041	7006 032 001-040			7006 080 002-020	8107 010 000-020	8115 010 000-020	7011 100 000-021
7006040000-021	7006 040 001-020	2355 052 038-067	7012 040 000-073	7006 065 002-020	8107 010 000-020	8115 010 000-020	7011 125 000-021
7006040000-041	7006 040 001-040			7006 125 002-020	8107 010 000-020	8115 010 000-020	7011 150 000-021
7006050000-021	7006 050 001-020	2355 064 050-067	7012 050 000-073	7006 065 002-020	8107 012 000-020	8115 012 000-020	
7006050000-041	7006 050 001-040			7006 150 002-020	8107 012 000-020	8115 012 000-020	
7006065000-021	7006 065 001-020	2355 079 066-067	7012 065 000-073	7006 065 002-020			
7006065000-041	7006 065 001-040						
7006080000-021	7006 080 001-020	2355 094 081-067	7012 080 000-073	7006 080 002-020			
7006080000-041	7006 080 001-040						
7006100000-021	7006 100 001-020	2355 114 100-067	7012 100 000-073	7006 100 002-020			
7006100000-041	7006 100 001-040						
7006125000-021	7006 125 001-020	2355 144 125-067	7012 125 000-073	7006 125 002-020			
7006125000-041	7006 125 001-040						
7006150000-021	7006 150 001-020	2355 169 150-067	7012 150 000-073	7006 150 002-020			
7006150000-041	7006 150 001-040						