

Operation manual

Dunos O50 F

Dunos O90 F

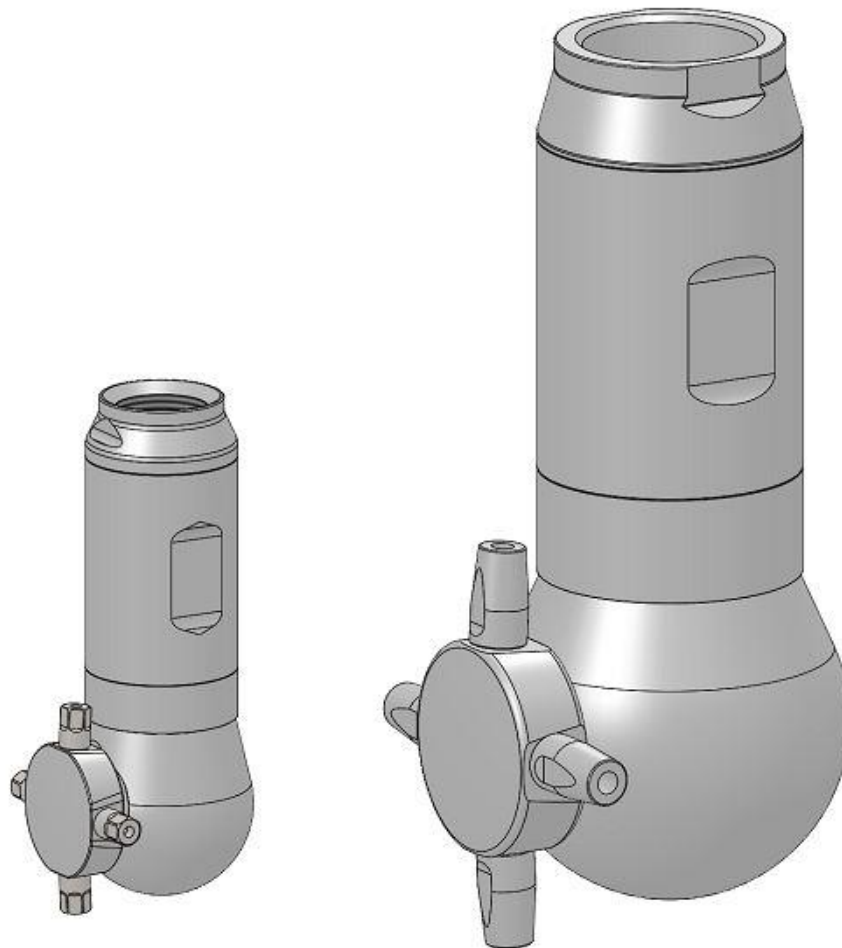



This operation manual is part of the jet cleaner and has to be available at all times for every user.

Every safety indication has to be communicated and considered. If the jet cleaner will be outreached, the operation manual has to be outreached too.

Contents:

1	General information	4
1.1	Operation	4
1.2	Intended use	4
1.2.1	Labelling.....	5
1.2.2	Conditions of operating.....	5
1.2.3	Dangers.....	6
2	Technical data	7
2.1	Dimensions DO50	8
2.2	Dimensions DO90	9
3	Service.....	10
4	Installation and initial operation.....	10
4.1	Placing of the jet cleaner.....	10
4.2	Mounting and operating stuff	11
4.3	Initial operation.....	11
5	Integration in a facility.....	12
5.1	Automatic control.....	12
5.2	Manual control	12
5.3	Emergency stop	12
6	Transport.....	13
6.1	Scope of delivery	13
6.2	Transport and packaging.....	13
7	Quality assurance	13
8	Disposal.....	14
9	Annexe	14
9.1	Used Symbols	14
9.2	Demand values Dunos O50 F VD.....	15
9.3	Demand values Dunos O90 F VD.....	17
10	Imprint	19

1 General information

1.1 Operation

The DUNOS O50 F and O90 F jet cleaner are orbital working jet cleaner. They are moved by the cleaning medium itself. The devices are configured with low dead storage and they are produced with certificated material in Germany. Surface and surface quality are subjected to permanent monitoring during production.

The cleaning medium has to be filtrated according specification. It is inducted into jet cleaner. The jet cleaner is installed directly to the vessel flange or to a supporting tube that rises into the vessel. Variable connectors are possible, standard connectors are described in the chapter „Technical data“. The streaming medium is directed through a turbine and with a gear in line it is generated an output speed of 10 to 14 rpm. The jet cleaner is driven through a driving shaft. The cleaning jet is striking with high impact on the wall. The pattern of the cleaning jet inside the vessel describes a laying eight. Using chemicals for cleaning has to be regulated by the operator depending on what contamination is existent.

Attention: Only a part of the medium flows through the gear drive. The main flow is directed through a bypass to the head with the nozzles. This is for reducing pressure loss and assuring maximum flow for the nozzles.

The jet cleaner are available with different diameter of nozzles for perfect adaption of cleaning task.

1.2 Intended use



Use the jet cleaner only in closed vessels. An operating outside of the vessel can result in serious injury because of the high strength of bounding jets. Furthermore cleaning medium is spacious spreaded through environment.



Back fitting and modification of the jet cleaner is forbidden and lead to expiration of the guarantee.

Another or beyond use will be reckoned as not intended use and is barred from liability of AquaDuna GmbH & Co KG.

1.2.1 Labelling

Every jet cleaner is labelled with a serial number.

1.2.2 Conditions of operating



For intended use of the jet cleaner the consideration of following conditions is highly necessary:

- You have to follow the mounting instruction (chapter 4).
- Using an pre-filter 500µm is inevitable.
- The allowed temperature for using the jet cleaner is about 4 - 120°C.

The operator guarantess for compyling with the operation manual.

1.2.3 Dangers



The jet cleaner are use with high pressure. We point out explicitly that the operating manual has to be followed. Damages as a result of non-compliance are not accepted by the producer.



Use the jet cleaner only in the intended area. Operating is only possible in closed vessels. Consider danger by rotating parts.



Don't turn the head of the jet cleaner by hand. You could damage the gear drive inside.



When operating with the jet cleaner do not put your hands between nozzles and head, you could pinch your fingers.



Installation and use can only be done by instructed and authorized staff.

2 Technical data

	DUNOS O50 F	DUNOS O90 F
Length:	131 mm	226 mm
Mounting diameter:	65 mm	125 mm
Connection thread:	G $\frac{3}{4}$ "	G1 $\frac{1}{2}$ "
Number of nozzles:	2 - 4	2 - 4
Nozzle diameter:	2 - 5 mm	5 - 8 mm
Working pressure:	3 - 12 bar	3 - 15 bar
Cleaning radius:	2,5 - 4,5 m	4 - 9 m
Spraying radius:	3,5 - 6 m	4 - 11 m
Weight:	0,8 kg	4,0 kg
Operating temperature:	4 - 120 °C	
Pre-filter:	500 μ m	
Materials in use:	stainless steel 1.4404 (316L)	
	PEEK TF 10	
	EPDM	
	Ceramics ZrO ₂	
Accessories (optional):	rotation supervision	
	Connecting parts	
	Special nozzles	

2.1 Dimensions DO50

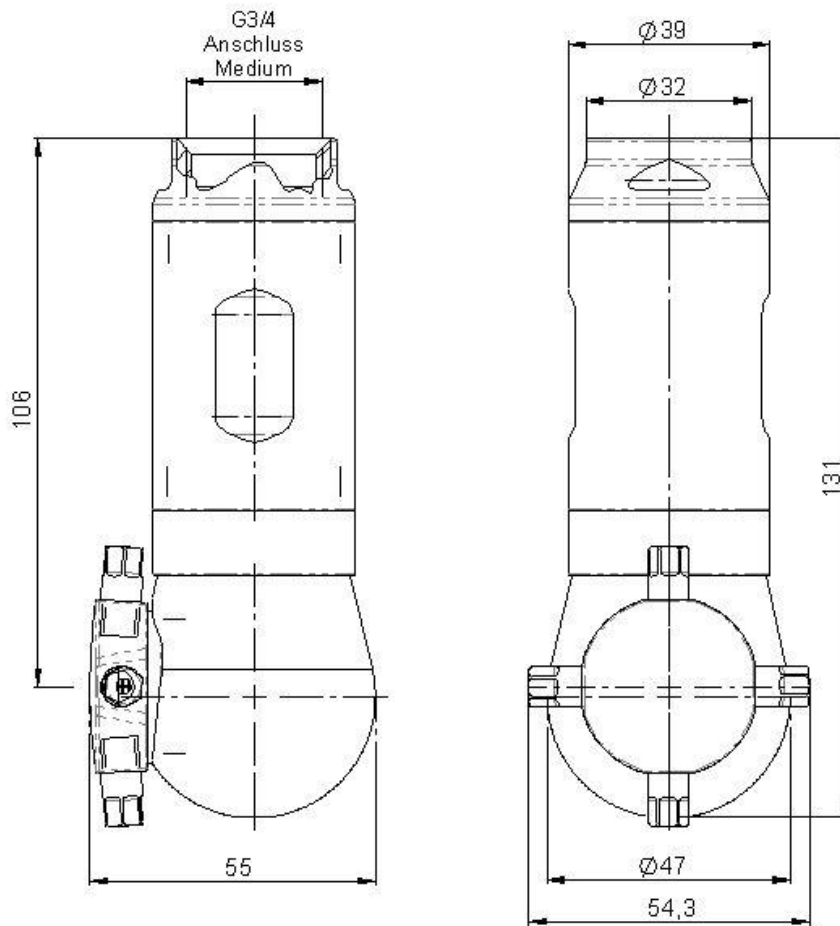

The dimensions can vary according to connection thread and nozzle diameter.

2.2 Dimensions DO90

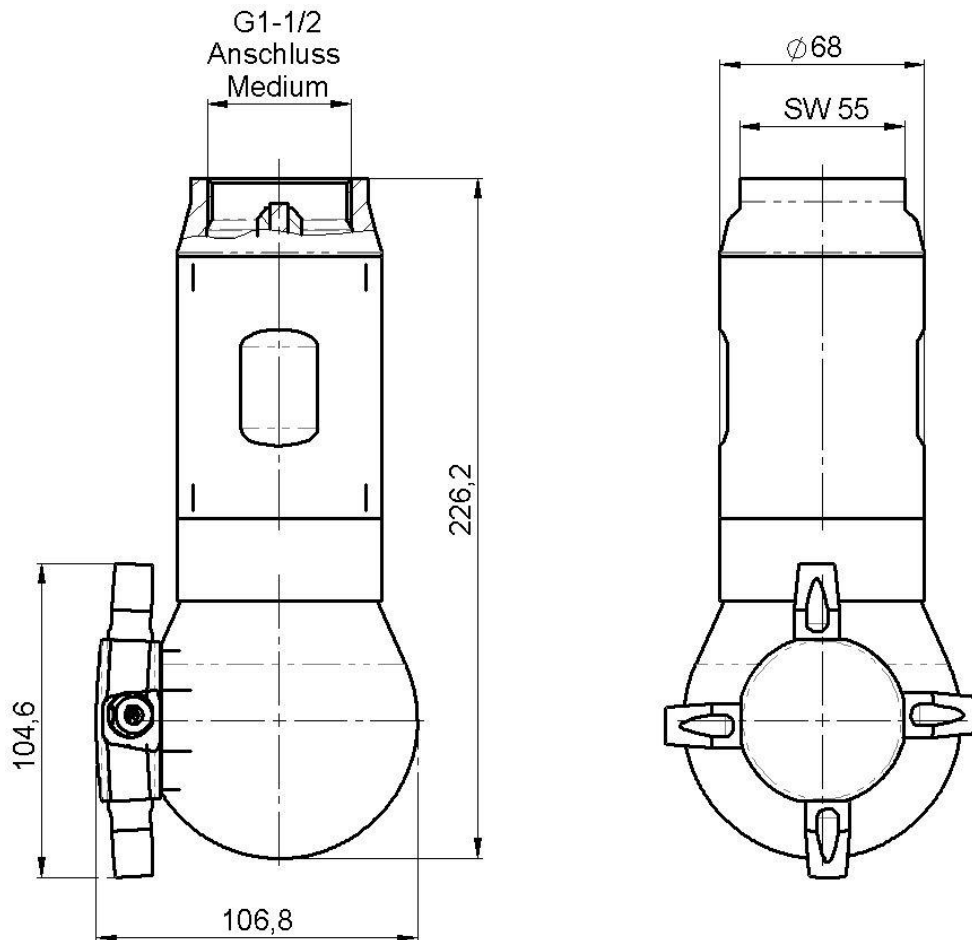

The dimensions can vary according to connection thread and nozzle diameter.

3 Service



Depending on the operating conditions the jet cleaner has to face a regular visual control of external damage, function of rotation and spraying pattern.

Maintenance from the manufacturer is recommended after a maximum of 300 operating hours. Depending on the prevalent operating conditions for example pressure, temperature, and properties of the medium or impact of the operator on the plant it could be necessary to do the maintenance earlier.

4 Installation and initial operation

4.1 Placing of the jet cleaner



Pay attention to the operation manual (chapter 1.2.3.).

The jet cleaner is mounted through a thread to the downpipe. For sealing the thread you can use a o-seal.

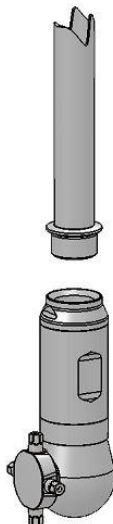

4.2 Mounting and operating staff

The operator has to guarantee that the mounting and operating staff is appropriate trained. Every person that deals with rotating and spraying devices has to be trained to know the dangers of the devices.

Stuff that is not listed for operating purposes mustn't stay in the operational area. The operator has to guarantee for that.

4.3 Initial operation



Pay attention to the operation manual (chapter 1.2.3.).

When all pipelines are fixed permanently with the jet cleaner and the shut-off valve is closed, then jet cleaner is prepared for use.

The pre-filter has to be controlled and the filter has to be inserted. (see chapter 2)

You have to rinse the feed pipe before initial operation of the jet cleaner. Metallic contamination and residues of welding can damage the jet cleaner.

Be sure that the feed pipe is deaerated before initial operation, especially in cases of long feeding pipes. That is needed for avoiding water hammers that can also damage the jet cleaner.

When using hand-operated fittings don't open them abruptly for avoiding water hammers.



When using the devices in automatic facilities the operating staff has to be familiar with the power shutdown and the emergency stop.

5 Integration in a facility

5.1 Automatic control

When using the jet cleaner in an automatic facility be sure that the function of the jet cleaner can be controlled. This can be done by rotation supervision or by visual control. When using visual control it has to be documented.

5.2 Manual control

When controlling the jet cleaner by manual control element be sure to avoid water hammers. Open and close the control elements slowly. When using steam consider the operating temperature, the boundaries mustn't be exceeded. Supervision has to be assured.

5.3 Emergency stop



For using an emergency stop the operating staff has to be familiar with the system concept.

It is absolutely necessary to train an emergency stop that the staff knows what to do. The training has to be documented. The operator has to guarantee correct operation, he is liable for possible damages, caused by maloperation.

6 Transport

6.1 Scope of delivery



The jet cleaner and the operation manual are part of the delivery. The type of jet cleaner that is delivered can be identified with the shipping documents.

6.2 Transport and packaging

Our products are produced, assembled and tested with extraordinary diligence. Should there still be any reason for complaining, we will satisfy you within the bounds of our warranty. Of course you can contact us beyond warranty.



With every delivery you have to verify packing list with the scope of delivery. After finding out completeness you have to check the goods in terms of damage.

If there should be any damage it has to be put on record on the shipping documents. Documentation of the damage has to be signed by the carrier.

For possible return delivery you have to use the original packaging. Or you have to choose an appropriate packaging that protects the devices from damage.

7 Quality assurance

Quality in design engineering, production, assembly and testing is self-evident for us. Quality is an obligatory requirement for a durable efficient and high grade production of our demanding products. For assuring our high quality demands we use an EDP based quality system that is certificated according to ISO 9001:2008. All our products face a 100% inspection to guarantee that only fully functional products leave our facility.

8 Disposal

All materials used for a jet cleaner are not harmful to the environment. Materials used are stainless steel, EPDM, ceramics and PEEK. Every compound can be de-polluted by the normal foreseen way.



Attention!! Make sure that there is no more contamination with substances from the operation. To be sure rinse the devices before the disposal.

9 Annexe

9.1 Used Symbols

Warning of danger



Danger of pinches



Danger by rotating parts



Pay attention to operation manual



Information



9.2 Demand values Dunos O50 F VD

pressure	flow		Connection thread ¾" Number of nozzles 4 Nozzle diameter 2,0
[bar]	[m³/h]	[l/min]	
1,0		0,0	
2,0	0,7	11,7	
3,0	0,9	15,0	
4,0	1,0	16,7	
5,0	1,1	18,3	
6,0	1,2	20,0	
7,0	1,3	21,7	
8,0	1,4	23,3	

pressure	flow		Connection thread ¾" Number of nozzles 4 Nozzle diameter 2,5
[bar]	[m³/h]	[l/min]	
1,0	1,0	16,7	
2,0	1,3	22,3	
3,0	1,5	25,3	
4,0	1,7	28,3	
5,0	1,9	32,0	
6,0	2,0	33,8	
7,0	2,2	37,2	
8,0	2,4	40,0	

pressure	flow		Connection thread ¾" Number of nozzles 4 Nozzle diameter 3,0
[bar]	[m³/h]	[l/min]	
1,0	0,9	15,0	
2,0	1,3	21,7	
3,0	1,6	26,7	
4,0	1,9	31,7	
5,0	2,1	35,0	
6,0	2,3	38,3	
7,0	2,4	40,0	
8,0	2,6	43,3	

pressure	flow		Connection thread $\frac{3}{4}$ " Number of nozzles 4 Nozzle diameter 4,0
[bar]	[m ³ /h]	[l/min]	
1,0	1,7	28,3	
2,0	2,5	41,7	
3,0	3,1	51,7	
4,0	3,5	58,3	
5,0	3,8	63,3	
6,0	4,1	68,3	
7,0	4,4	73,3	
8,0	4,7	78,3	

pressure	flow		Connection thread $\frac{3}{4}$ " Number of nozzles 4 Nozzle diameter 5,0
[bar]	[m ³ /h]	[l/min]	
1,0	2,1	35,0	
2,0	3,0	50,0	
3,0	3,7	61,7	
4,0	4,3	71,7	
5,0	4,8	80,0	
6,0	5,2	86,7	
7,0	5,5	91,7	
8,0	5,9	98,3	

9.3 Demand values Dunos O90 F VD

pressure	flow		Connection thread 1 ½" Number of nozzles 4 Nozzle diameter 4,0
[bar]	[m³/h]	[l/min]	
1,0	2,2	36,7	
2,0	3,2	53,3	
3,0	3,9	65,0	
4,0	4,4	73,3	
5,0	4,9	81,7	
6,0	5,3	88,3	
7,0	5,7	95,0	
8,0	6,1	101,7	

pressure	flow		Connection thread 1 ½" Number of nozzles 4 Nozzle diameter 5,0
[bar]	[m³/h]	[l/min]	
1,0	3,3	55,0	
2,0	4,8	80,0	
3,0	5,8	96,7	
4,0	6,7	111,7	
5,0	7,4	123,3	
6,0	8,0	133,3	
7,0	8,5	141,7	
8,0	9,0	150,0	

pressure	flow		Connection thread 1 ½" Number of nozzles 4 Nozzle diameter 6,0
[bar]	[m³/h]	[l/min]	
1,0	4,7	78,3	
2,0	6,4	106,7	
3,0	7,8	130,0	
4,0	8,8	146,7	
5,0	9,5	158,3	
6,0	10,3	171,7	
7,0	11,0	183,3	
8,0	11,6	193,3	

pressure	flow		Connection thread 1 ½“ Number of nozzles 4 Nozzle diameter 7,0
[bar]	[m ³ /h]	[l/min]	
1,0	6,0	100,0	
2,0	8,1	135,0	
3,0	9,7	161,7	
4,0	11,1	185,0	
5,0	12,3	205,0	
6,0	13,4	223,3	
7,0	14,3	238,3	
8,0	15,1	251,7	

pressure	flow		Connection thread 1 ½“ Number of nozzles 4 Nozzle diameter 8,0
[bar]	[m ³ /h]	[l/min]	
1,0	7,4	123,3	
2,0	9,9	165,0	
3,0	11,9	198,3	
4,0	13,6	226,7	
5,0	15,1	251,7	
6,0	16,4	273,3	
7,0	17,5	291,7	
8,0	18,5	308,3	

10 Imprint

Original operation manual

Dunos O50 F / Dunos O90 F

Stand march 2016

Revision 00

AquaDuna GmbH & Co.KG

Ferdinand-von-Steinbeis-Ring 31

D-75447 Sternefels

Tel.: 07045 / 204980

Fax.: 07045 / 204990

www.aquaduna.com