



# guth ventile

FLUID PROCESS GROUP

Translation of the original

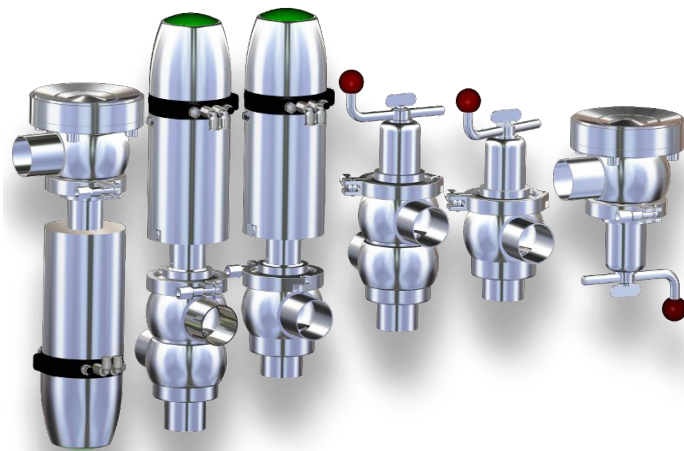

## Operating instruction

### 55xx - KI-DS



## **Guth Ventiltechnik GmbH**

Horstring 16  
D - 76829 Landau

 +49(0) 6341 5105-0 •  +49(0) 6341 5105-85  
www.guth-vt.de • sales@guth-vt.de

---

Copyright: © FLUID PROCESS GROUP

Guth Ventiltechnik GmbH is responsible for the content, completeness and correctness of the document.

## Table of contents

<b>1</b>	<b>General informations .....</b>	<b>4</b>
1.1	Informations for your safety .....	4
1.2	Marking of security instructions.....	4
1.3	General designated use .....	4
1.4	Personnel.....	4
1.5	Modifications, spare parts, accessories .....	4
1.6	General instructions .....	5
<b>2</b>	<b>Safety instructions.....</b>	<b>6</b>
2.1	General notes.....	6
2.2	Intended use .....	6
2.3	General safety instructions.....	6
<b>3</b>	<b>Delivery, transport and storage .....</b>	<b>8</b>
3.1	Delivery.....	8
3.2	Transport.....	8
3.3	Storage.....	8
<b>4</b>	<b>Specification.....</b>	<b>9</b>
4.1	Modular system.....	9
4.2	Valve types.....	10
<b>5</b>	<b>Function and operation .....</b>	<b>11</b>
5.1	Description of function.....	11
5.2	Valve basic position: .....	12
5.3	Control system and position indicator .....	13
5.4	Pneumatic valve activation.....	14
<b>6</b>	<b>Commissioning, service and maintenance .....</b>	<b>15</b>
6.1	Commissioning.....	15
6.1.1	Installation instructions.....	15
6.1.2	General welding guidelines .....	15
6.1.3	ATEX - Guidelines .....	15
6.2	Maintenance .....	15
6.3	Cleaning .....	16
<b>7</b>	<b>Technical data .....</b>	<b>17</b>
7.1	Operating pressure.....	18
<b>8</b>	<b>Disassembly and assembly .....</b>	<b>20</b>
8.1	Valves with manual operating .....	20
8.2	Valves with pneumatic operation.....	22
8.3	Tank outlet valve .....	25
<b>9</b>	<b>Drawings and dimensions .....</b>	<b>27</b>
9.1	Drawings .....	27
9.2	Dimensions .....	29
9.3	Control units .....	33
<b>10</b>	<b>Wearing parts .....</b>	<b>34</b>
10.1	Wearing parts list.....	34
10.2	Wear parts kit.....	36
<b>11</b>	<b>Classification.....</b>	<b>38</b>
11.1	Structure of Order Number .....	38
<b>12</b>	<b>Appendix .....</b>	<b>40</b>
12.1	Declaration of incorporation.....	40

# 1 General informations

## 1.1 Informations for your safety

We are pleased that you have decided for a high-class Guth Ventiltechnik GmbH product. With correct application and adequate maintenance, our products provide long time and reliable operation.





Before installation and initiation, please carefully read this instruction manual and the security advices contained in it. This guarantees reliable and safe operation of this product and your plant respectively. Please note that an incorrect application of the process components may lead to great material damages and personal injury.

In case of damages caused by non observance of this instruction manual, incorrect initiation, handling or external interference, guarantee and warranty will lapse!

Our products are produced, mounted and tested with high diligence. However, if there is still a reason for complaint, we will naturally try to give you entire satisfaction within the scope of our warranty. We will be at your disposal also after expiration of the warranty. In addition, you will also find all necessary instructions and spare part data for maintenance in this instruction manual. If you don't want to carry out the maintenance by yourself, our Guth Ventiltechnik GmbH - service team will naturally be at your disposal.

## 1.2 Marking of security instructions

Hints are available in the chapter "safety instructions" or directly before the respective operation instruction. The hints are highlighted with a danger symbol and a signal word. Texts beside these symbols have to be read and adhered to by all means. Please continue with the text and with the handling at the valve only afterwards.

Symbol	Signal word	Meaning
	DANGER	Imminent danger which will result severe personal injury or death.
	WARNING	Imminent danger which may result severe personal injury or death.
	CAUTION	Dangerous situation which may cause slight personal injury or material damages.
	NOTICE	An harmful situation which may result in damages of the product itself or of adjacent vicinity.
	INFORMATION	Marks application hints and other information which is particularly useful.

## 1.3 General designated use

The fitting is designed exclusively for the purposes described below. Using the fitting for purposes other than those mentioned is considered contrary to its designated use. Guth Ventiltechnik GmbH cannot be held liable for any damage resulting from such use. The risk of such misuse lies entirely with the user. The prerequisite for the reliable and safe operation of the fitting is proper transportation and storage as well as competent installation and assembly. Operating the fitting within the limits of its designated use also involves observing the operating, inspection and maintenance instructions.

## 1.4 Personnel

Personnel entrusted with the operation and maintenance of the tank safety system must have the suitable qualification to carry out their tasks. They must be informed about possible dangers and must understand and observe the safety instructions given in the relevant manual. Only allow qualified personnel to make electrical connections.

## 1.5 Modifications, spare parts, accessories

Unauthorized modifications, additions or conversions which affect the safety of the fitting are not permitted. Safety devices must not be bypassed, removed or made inactive. Only use original spare parts and accessories recommended by the manufacturer.

## 1.6 General instructions

The user is obliged to operate the fitting only when it is in good working order. In addition to the instructions given in the operating manual, please observe the relevant accident prevention regulations, generally accepted safety regulations, regulations effective in the country of installation, working and safety instructions effective in the user's plant.

## 2 Safety instructions

### 2.1 General notes



#### NOTICE - observe the operating instructions

To avoid danger and damage, the fitting must be used in accordance with the safety instructions and technical data contained in the operating instructions.



#### NOTICE

All data are in line with the current state of development. Subject to change as a result of technical progress.

### 2.2 Intended use

The Single seat valve is used in the beverage and food industry, in pharmaceutical, bio-engineering, as well as in chemical engineering.

Inclined seat valves, Angle valves, T-valves, Cross valves, Loop valves and Tank outlet valves are used as manually or pneumatically controlled Shut-off valves, Change-over valves are used as Multi-port valves in industrial installations.

### 2.3 General safety instructions



#### ⚠ WARNING

##### Risk of injury by moving parts

Do not grab into the valve when the actuator is pressurized. Limbs can be crushing or amputating.

- Remove the control air line before dismantling.
- Ensure that the actuator is unpressurized.



#### ⚠ WARNING

##### Risk of injury by moving parts

When dismantle the clamp coupling, the spring preloaded valve insert (air open - spring close) may incur serious injuries by jumping out of the housing.

- First pneumatically open the valve before disassembling the clamp coupling, so that upstroke the piston.
- Dismount the valve insert.
- Remove the control air line at valve insert.

⇒ Ensure that the actuator is unpressurized.



#### ⚠ WARNING

##### Risk of injury by outflowing medium

Dismantling the valve or valve assemblies from the plant can cause injuries.

- Medias flowing through the leakage drain outlet are to be drained off without splashing into a discharge arrangement.
- Carry the disassembling only if when the plant has been rendered pressure-less and free of liquid and gas.



#### ⚠ WARNING

##### ATEX - Guidelines

If the valve or the plant is operated in a potentially explosive atmosphere, the valid ATEX directive of the EC and the installation instructions in this operating manual must be observed.

**⚠ CAUTION**

When mounting the clamps, the max. torque must not be exceeded.  
(see technical data)

**⚠ CAUTION**

To avoid air leaking, only use pneumatic connection parts that have an O-ring seal facing the even surface.

**⚠ CAUTION**

Before starting the system, the entire pipeline system must be thoroughly cleaned.

**⚠ CAUTION**

Steps should be taken to ensure that no external forces are exerted on the fitting.

## 3 Delivery, transport and storage

### 3.1 Delivery

- Immediately after receipt check the delivery for completeness and transport damages.
- Remove the packaging from the product.
- Retain packaging material, or expose of according to local regulations.

### 3.2 Transport



#### CAUTION

##### **Risk of injury and damage to the product**

During the transport the generally acknowledged rules of technology, the national accident prevention regulations and company internal work and safety regulations must be observed.

### 3.3 Storage



#### NOTICE

##### **Damage to the product due to improper storage!**

Observe storage instructions

avoid a prolonged storage



#### INFORMATION

##### **Recommendation for longer storage**











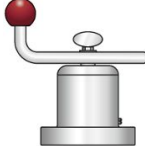

We recommend regularly checking the product and the prevailing storage conditions during long storage times.

- To avoid damage to seals and bearings,
  - products up to DN 125 / OD 5 inch should be stored horizontally for maximum 6 months.
  - products larger than DN 125 / 5 inch, should be stored in the upright position with the actuator on top.
- Don't store any objects on the products.
- Protect the products for wetness, dust and dirt.
- The product should be stored in a dry and well ventilated room at a constant temperature (optimal indoor temperature: 25 C ±5 ; indoor humidity data 70% ±5%).
- Protect seals, bearings and plastic parts for UV light and ozone.

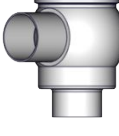
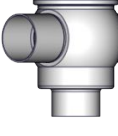
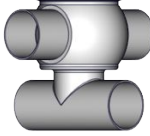
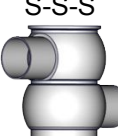
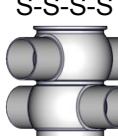

## 4 Specification

### 4.1 Modular system

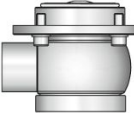
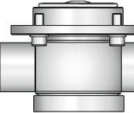
KI-Top control head		feedback unit	
 Stainless steel hood	 Transparent hood	 Feedback unit with finger guard (E)	
Actuator manual		Actuator pneumatical	
 Manual operation	 ø104	 ø129	
	 ø167	 ø230	
Valve inserts			
for Angle valves			for Two way valves
HNBR, EPDM, FKM			
Valve housing			
 Inclined seat valve	 Angle valve		 t-valve
 cross valve	 S-S-S	 S-S-S-S	 Loop valve
Two-way-changeover valve			
 S		 SS	
Tank outlet valve			

## 4.2 Valve types

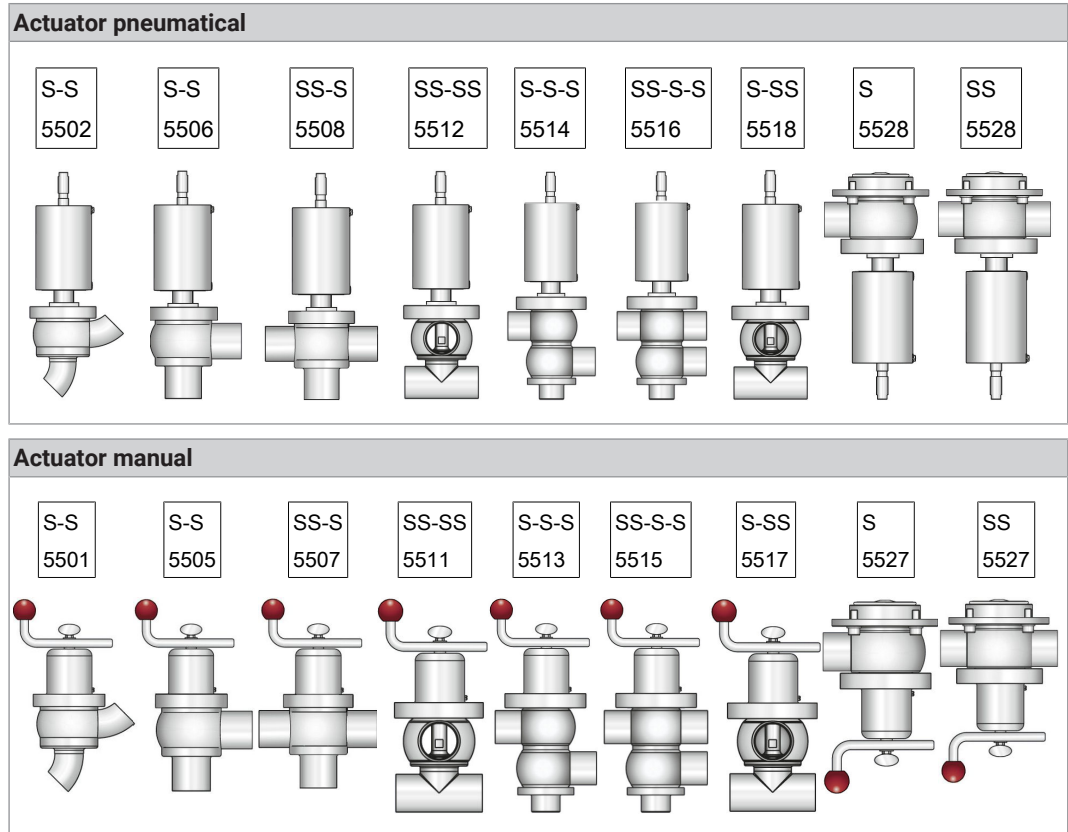

## 5 Function and operation

### 5.1 Description of function

Valve function:	<ul style="list-style-type: none"> <li>Inclined seat valve, Angle valve, T-valve, Cross valve, Loop valve, Tank outlet valve             <ul style="list-style-type: none"> <li>Shut off fluid media in pipelines (see Fig.A and B)</li> </ul> </li> <li>Changeover valve             <ul style="list-style-type: none"> <li>Control fluid media in pipelines (see Fig.A and B)</li> </ul> </li> </ul>
Operation:	<ul style="list-style-type: none"> <li>pneumatic operation by a lift drive (air/spring or air/air)</li> <li>manual operation by a crank-handle (open ☺ / close ☻)</li> </ul>
Activation:	<ul style="list-style-type: none"> <li>Pneumatically over a 3/2-way solenoid valve (see "Pneumatic valve activation")</li> </ul>

#### Description of function - Lift actuator

<b>Normally closed (NC) Basic position: Valve close</b>	
pneum. operated	→ opens the valve
undivided pneum. operated	→ spring force closes the valve

<b>normal open (NO) Basic position: Valve open</b>	
pneum. operated	→ valve "CLOSE"
undivided pneum. operated	→ spring force opens the valve

<b>double acting (DA) Basic position: not defined<sup>1</sup></b>	
pneum. operated	→ opens the valve
undivided pneum. operated	→ valve "CLOSE"

1. The valve position is not defined in case of decrease of pressure in the compressed air line.

### 5.2 Valve basic position:



#### INFORMATION

- Actuator AIR/AIR : Valve assemblies with double acting actuators will fall into an un-defined stroke position.
- Actuator AIR/SPRING: The basic position of the valve is closed or opened depending on the kind of actuator.

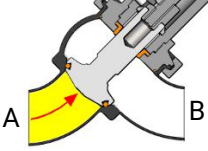
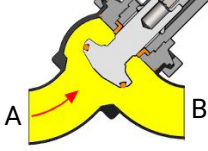
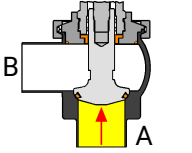
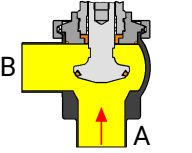
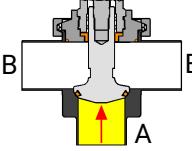
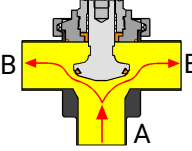
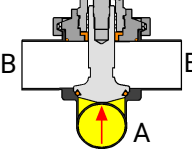
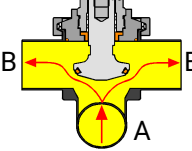
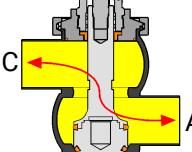
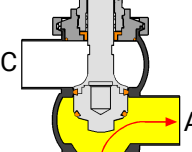
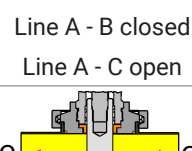
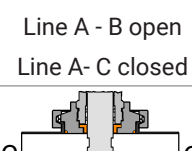
Basic positon: Kind of actuation:	Valve closed Normally closed (NC)	Valve open Normally open (NO)
<b>Type: 5502</b> <b>S-S</b> Inclined seat valve	 Line A - B closed	 Line A - B open
<b>Type: 5506</b> <b>S-S</b> Angle valve	 Line A - B closed	 Line A - B open
<b>Type: 5508</b> <b>SS-S</b> t-valve	 Line A - B closed	 Line A - B open
<b>Type: 5512</b> <b>SS-SS</b> cross valve	 Line A - B closed	 Line A - B open
<b>Type: 5514</b> <b>S-S-S</b> Changeover valve	 Line A - B closed Line A - C open	 Line A - B open Line A - C closed
<b>Type: 5516</b> <b>SS-S-S</b> Changeover valve	 Line A - B closed Line A - C open	 Line A - B open Line A - C closed

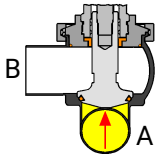
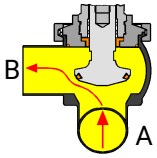
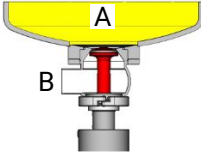
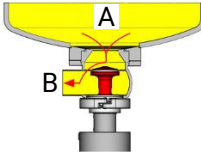
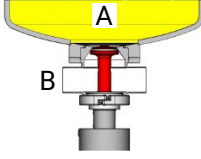
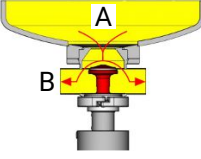
Basic position: Kind of actuation:	Valve closed Normally closed (NC)	Valve open Normally open (NO)
<b>Type: 5518</b> <b>S-SS</b> Loop valve	 <p>Line U - A closed</p>	 <p>Line U - A open</p>
<b>Type: 5528</b> <b>S</b> Tank outlet valve	 <p>Line A - B closed</p>	 <p>Line A - B open</p>
<b>Type: 5528</b> <b>SS</b> Tank outlet valve	 <p>Line U - AB closed</p>	 <p>Line U - AB open</p>

### 5.3 Control system and position indicator



#### Feedback unit -optional-

Optionally, modular valve control head systems can be installed to the actuator for reading and actuating valve positions. The standard version is a closed system with SPS or ASI-bus switch-on electronics, and integrated 3/2-way solenoid valves. For tough operating conditions we recommend employing a high-grade steel cover.



#### Feedback unit with finger guard -optional-

For the acquisition of the valve positions over inductive initiators (Sensors), a feedback unit is mounted on the actuation. The enquiry takes place over the position of the piston rod.

### 5.4 Pneumatic valve activation

- MV = solenoid valve
- R = de-aeration, sound absorber
- P = compressed-air inlet
- LA = air supply
- S = Slide switch for manual operation of the solenoid valve
- Si = Sensor inductive
- E = sensor mounting

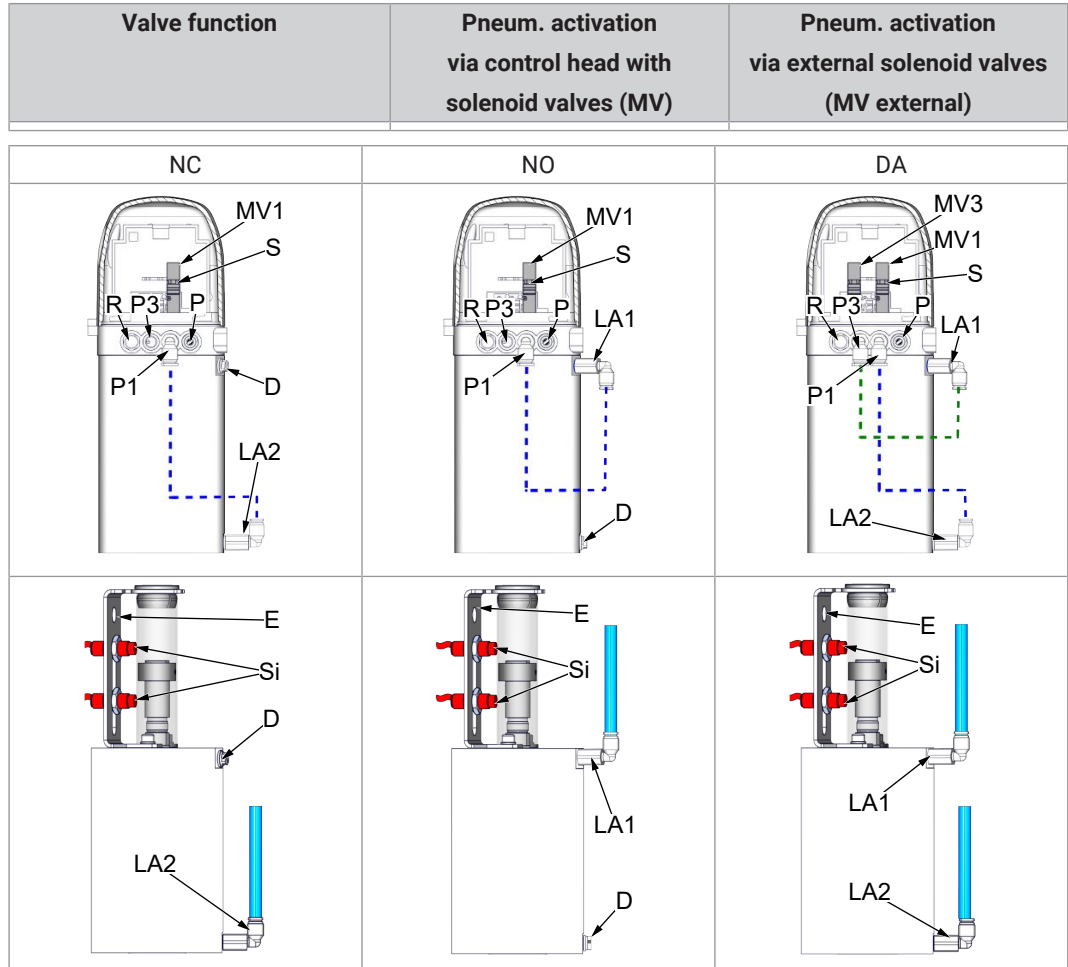

<b>Antriebsart: normal closed (NC)</b>		
<b>Valve OPEN</b> by pressurised air	control air feed P → MV1 → P1/LA2	control air feed ext. MV → LA2
<b>Valve CLOSED</b> by spring tension	de-aeration LA2/P1 → MV1 → R	de-aeration LA2 → ext. MV
<b>Kind of actuator: air open - air close (DA)</b>		
<b>Valve OPEN</b> by pressurised air	control air feed P → MV1 → P1/LA2	control air feed ext. MV → LA2
<b>Valve CLOSED</b> by pressurised air	control air feed P → MV3 → P3/LA1	control air feed ext. MV → LA1
<b>Kind of actuator: normal open (NO)</b>		
<b>Valve OPEN</b> by spring tension	de-aeration P1/LA1 → MV1 → R	de-aeration LA1 → ext. MV
<b>Valve CLOSED</b> by pressurised air	control air feed P → MV1 → P1/LA1	control air feed ext. MV → LA1

## 6 Commissioning, service and maintenance

### 6.1 Commissioning

#### 6.1.1 Installation instructions

##### Fitting position

- The installation position is without importance.



#### NOTICE

If installed horizontally, some minor residual liquids will remain in the ball-shape of the housing.

#### 6.1.2 General welding guidelines

Sealing elements integrated in weld components must generally be removed prior to welding. To prevent damage, welding should be undertaken by certified personnel (EN ISO 9606-1). Use the TIG (Tungsten Inert Gas) welding process.



#### CAUTION

##### Damage and injuries due to high temperature supply

To avoid a distortion of the components, all welding parts must be welded to stress-relieved. Allow all components to cool before assembling.



#### NOTICE

##### Damage due to impurities

Impurities can cause damage to the seals and seals area. Clean inside areas prior to assembly.

#### 6.1.3 ATEX - Guidelines

For valves or plants/installations that are operated in the ATEX area, sufficient bonding (grounding) must be ensured (see valid ATEX Guidelines EG).

### 6.2 Maintenance



#### RECOMMENDATION

##### Replacement of seals

To achieve optimal maintenance cycles, the following points must be observed!

- When replacement of seals, all product-contacting seals should be replaced.
- Only original spare parts may be installed.

##### Maintenance interval

The maintenance intervals depend on the operating conditions "temperature, temperature-intervals, medium, cleaning medium, pressure and opening frequency". We recommend replacing the seals. The user, however should establish appropriate maintenance intervals according to the condition of the seals.

##### Lubricant recommendation

	EPDM; HNBR; NBR; FKM; k-flex	- Klüber Paraliq GTE703*
	Silicone	- Klüber Sintheso pro AA2*
	Thread	- Interflon Food*
*) It is only permitted to use approved lubricants, if the respective fitting is used for the production of food or drink. Please observe the relevant safety data sheets of the manufacturers of lubricants.		

### **Maintenance - Lift actuator**

The actuator is maintenance-free and non-removable.

## **6.3 Cleaning**

Cleaning of the inner housing is performed with the pipe cleaning system.



## 7 Technical data

<b>Model:</b>	KI-DS Single seat valves	
<b>Valve size:</b>	DIN: DN25 - DN100 Inch: 1" - 4"	
<b>Connections:</b>	weld-on end	
<b>Temperature range:</b>	Ambient temperature: Operating temperature: Sterilization temperature:	+4 to +45°C (air) +0 to +95°C (medium dependent) HNBR +120°C (SIP 30 min) EPDM +140°C (SIP 30 min) FKM +110°C (SIP 30 min)
<b>Pressure nominal (bar):</b>	PN16	
<b>Leak rate:</b>	A (DIN EN 12266-1)	
<b>Control air:</b> to DN 65 1/2 from DN 80 / 3"	<u>Control air pressure:</u> 5,5 - 8,0 bar 6,0 - 8,0 bar	<u>Quality of control air:</u> ISO 8573-1 : 2001 quality class 3
<b>Materials:</b> (in product contact)	Stainless steel:	1.4404 / AISI316L
	Surfaces:	Ra < 0,8µm metallic bright, e-polished
	Sealing material:	EPDM (FDA) HNBR (FDA) FKM (FDA)

### Torques

DN	25	40	50	65	80	100
Inch	1	1½	2	2½	3	4
<b>Clamp coupling (Nm):</b>	15	15	15	25	25	55

## 7.1 Operating pressure

### Operating pressure for valves with manual operating

DN Inch	25 1	40 1½	50 2	65 2½	80 3	100 4
Kind of actuator	crank handle	crank handle	crank handle	crank handle	crank handle	crank handle
	A   B   C	A   B   C	A   B   C	A   B   C	A   B   C	A   B   C
Valves with manual operating	10	10	10	10	10	10

### Operating pressure for valves with pneumatic operating

Nominal diameter	stroke mm	ØZ mm	Operating direction	Opening pressures / closing pressures [bar]								KVS	
				Size of actuator (ØA)								A → B m³/h	B → A m³/h
				ø104		ø129		ø167		ø230			
A	B	A	B	A	B	A	B						
DN 25 OD 1"	18 14	13 11	NC ↓ NO ↑	10,5 8,4	10,7 11,3	15,3 13,6	16 16	- -	- -	- -	- -	21	24
DN 40 OD 1½"	30 26,5	24,5 22	NC ↓ NO ↑	8,2 6,0	12,3 14,1	12,0 12,1	16 16	- -	- -	- -	- -	43	47
DN 50 OD 2"	24 21,5	15,8 13,6	NC ↓ NO ↑	6,0 6,5	9,0 8,0	9,8 9,7	13,8 13,7	16 16	16 16	- -	- -	82	77
DN 65 OD 2½"	24 18	15,2 10,6	NC ↓ NO ↑	- -	- -	6,0 6,0	8,0 8,0	12,5 9,9	12,4 15,3	- -	- -	145	138
DN 80 OD 3"	28,5 28,5	19,0 19	NC ↓ NO ↑	- -	- -	- -	- -	9,0 6,3	8,7 11,2	13,5 13,6	16 16	200	212
DN 100 OD 4"	28,5 26	18,2 16,2	NC ↓ NO ↑	- -	- -	- -	- -	6,0 4,2	5,6 7,3	9,2 9,2	12,7 12,3	274	299

Table 1 \*) Control air pressure: 5,5 bar

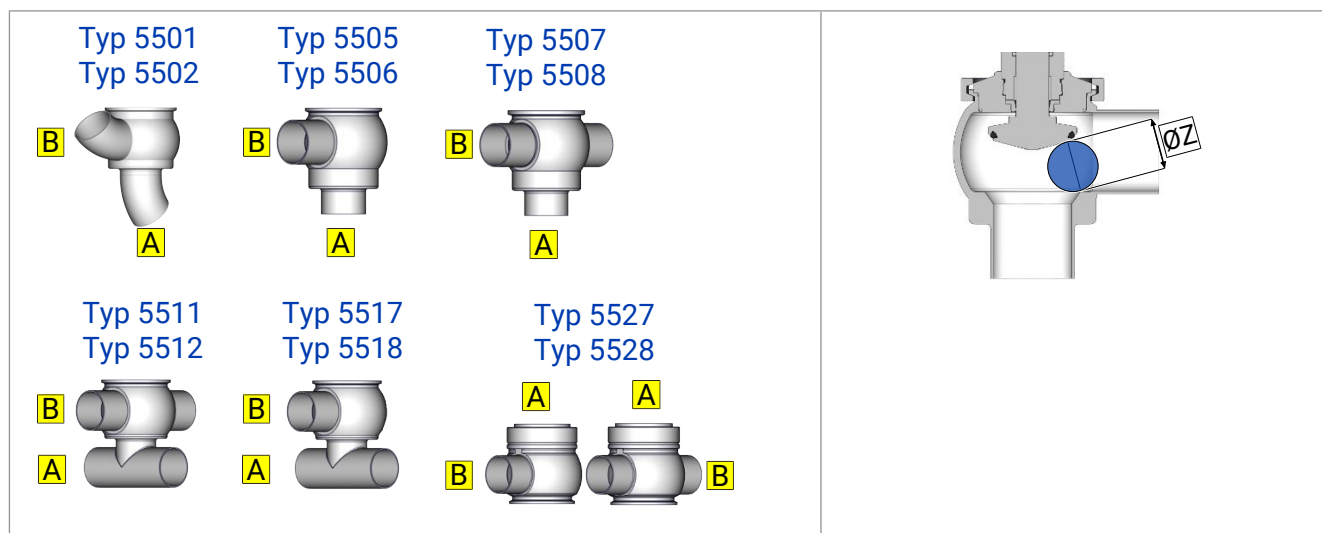

## Operating pressure for pneumatic changeover valves

Nominal diameter	stroke	Operating direction	Opening pressures / closing pressures [bar]												KVS	
			Size of actuator (ØA)												A → B	B → A
			Ø104			Ø129			Ø167			Ø230			m³/h	m³/h
	mm		A	B	C	A	B	C	A	B	C	A	B	C	m³/h	m³/h
DN 25 OD 1"	21	NC ↓	8,0	8,9	6,8	13,8	15,5	10,3	-	-	-	-	-	-	23	15
	17	NO ↑	8,3	8,6	7,1	13,3	13,7	12,1	-	-	-	-	-	-		
DN 40 OD 1½"	28,5	NC ↓	8,0	7,7	6,8	13,8	13,4	10,3	-	-	-	-	-	-	46	35
	25,5	NO ↑	7,8	7,4	7,1	12,5	11,6	12,1	-	-	-	-	-	-		
DN 50 OD 2"	34	NC ↓	8,0	7,0	6,8	13,8	12,1	10,3	-	-	-	-	-	-	67	55
	31,5	NO ↑	7,4	6,6	7,1	11,9	10,3	12,1	-	-	-	-	-	-		
DN 65 OD 2½"	31	NC ↓	-	-	-	8,7	7,1	6,5	16,1	15,0	10,2	-	-	-	126	83
	25,5	NO ↑	-	-	-	8,8	7,2	6,6	13,6	10,6	14,1	-	-	-		
DN 80 OD 3"	31	NC ↓	-	-	-	-	-	-	7,1	7,5	5,3	11,1	12,3	12,0	194	140
	28,5	NO ↑	-	-	-	-	-	-	7,2	7,5	5,4	14,7	16,4	8,5		
DN 100 OD 4"	34	NC ↓	-	-	-	-	-	-	6,9	5,5	5,3	11,1	9,2	12,2	260	166
	34	NO ↑	-	-	-	-	-	-	7,0	5,5	5,4	13,5	11,4	9,4		

Typ 5513  
Typ 5514

Typ 5515  
Typ 5516

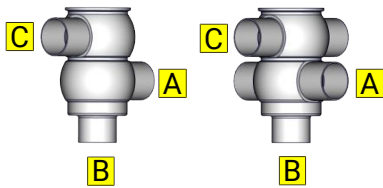



Table 2 \*) Control air pressure: 5,5 bar

## 8 Disassembly and assembly

### 8.1 Valves with manual operating

#### Mounting tools

T1		Combination wrench-Set	SW 8 - SW 24	-
T10		Joint -pin wrench	Pin Ø6	8027000065-000



#### NOTICE

All screw connections have right-handed threads.

#### Assembly valve insert

- Unscrew the clamp coupling (VK).
- Dismount the valve insert (VE2) out of the housing.

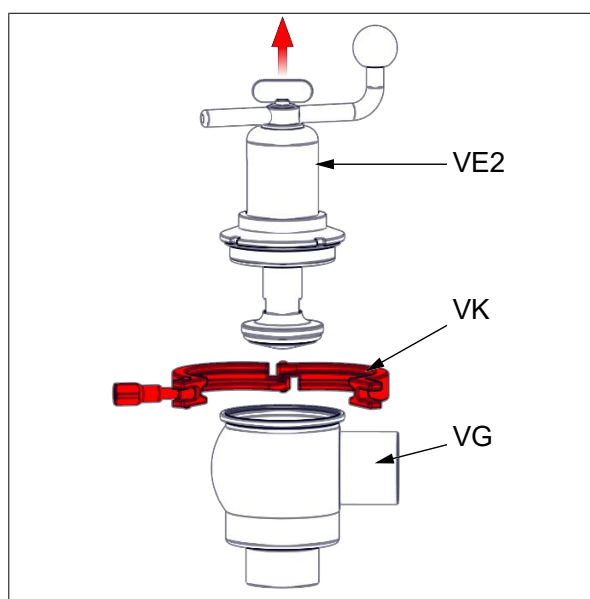

#### Replacement wear parts

- Unscrew the wing screw (19).
- Remove the crank handle (17), the discs (15) and (16).

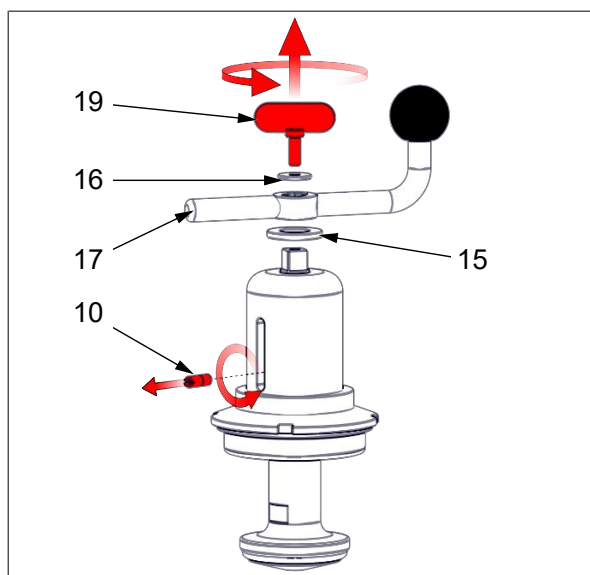

- **Changeover valve:** Unscrew the piston plate (9) from piston (1b) (SW1/SW2).
- Remove seal (D7) and O-ring (D6).
- Unscrew the piston (1a) resp. (1b) from spindle (11) (SW2/SW5).
- Remove O-ring (D1).

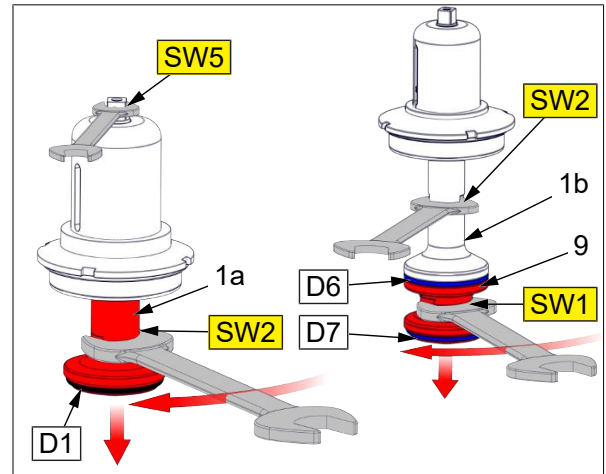

- Unscrew the insert (2) from the lantern (14) (use a hook wrench). Remove O-ring (D2) and seal (D3).

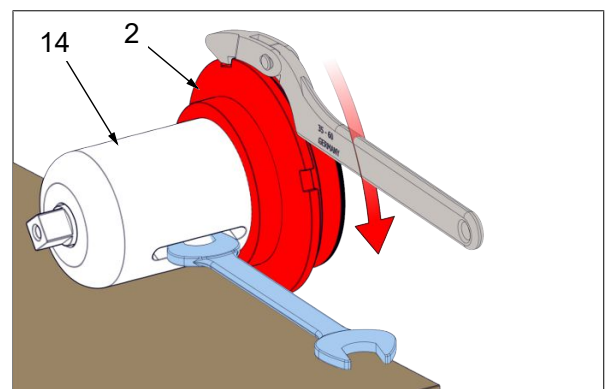



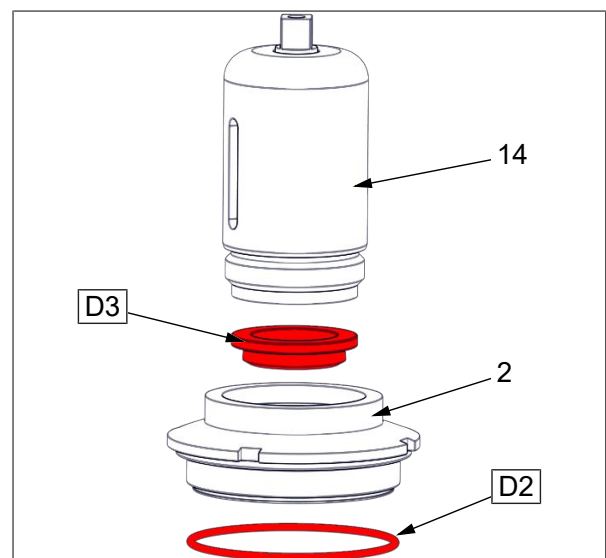

#### NOTICE!

- Puncture the O-ring (D1) and (D7) with a needle and remove them carefully from the groove of piston.
- Bearing bush (3) and the scraper ring (13) do not need to be removed for a seal change. The positions are not included in the seal set. If they are worn, please order them (see wearing parts set).



## 8.2 Valves with pneumatic operation

T1		Combination wrench-Set	SW 8 - SW 24	-
T10		Joint -pin wrench	Pin Ø6	8027000065-000
T11		Hinged hook wrench	-	8027000065-000
T12		Joint face wrench	Pin Ø6 40-80 MM	8028340080-000



### NOTICE

All threaded joint have right-hand thread.

Unscrew and remove control air, steam resp. cleaning lines and electrical lines, complete feedback unit or control head.

### Assembly valve insert

- Connect compressed air to LA2 and pressurize the actuator with air.
  - The piston retracts.

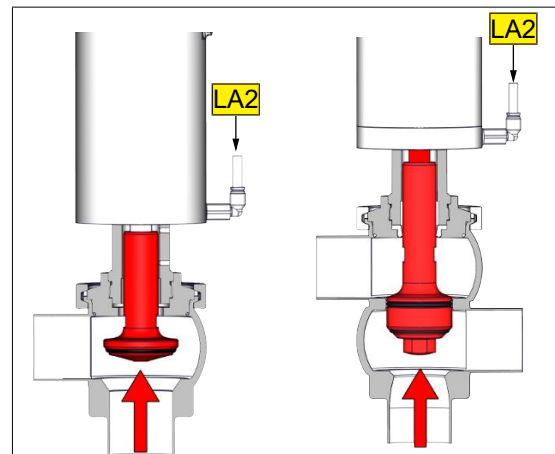

- Unscrew the clamp coupling (VK).
- Remove the complete valve insert with the upper shaft seal (D1) from the housing (VG).
- Disconnect compressed air at LA2 and depressurize the drive - The valve piston move in.
  - The valve piston returns to the basic position.

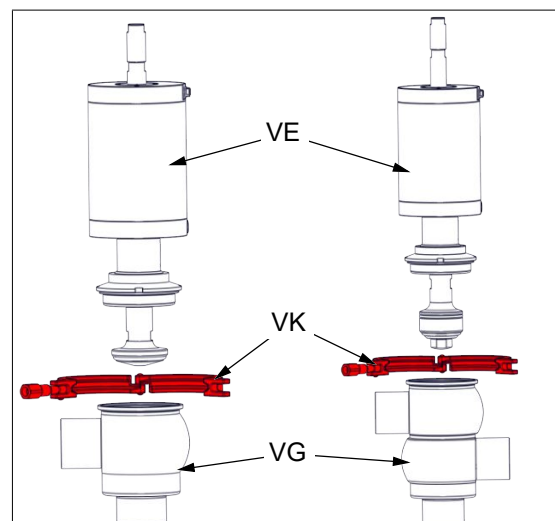

### Replacement wear parts - Valve insert (VE)

- **Changeover valve:** Unscrew the piston plate (9) from piston (1b) (SW1/SW2).
- Remove seal (D7) and O-ring (D6).
- Unscrew the piston (1a) resp. (1b) from spindle (6) (SW2/SW4).
- Remove O-ring (D1).

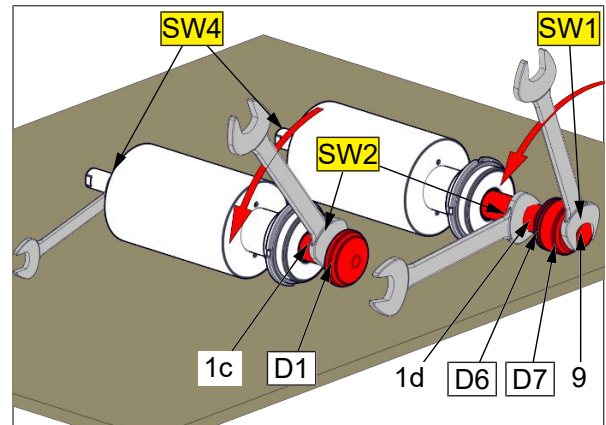

- Unscrew the insert (2) from the lantern (4) (use a hook wrench).
- Remove O-ring (2) and seal (D3).

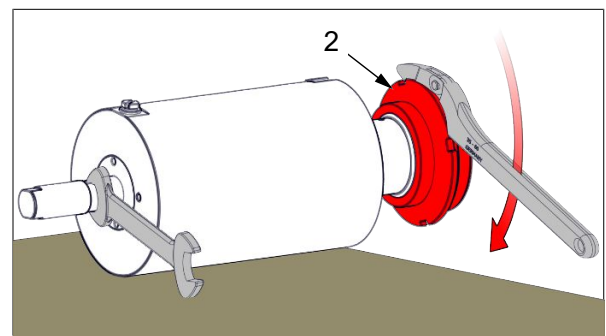

- Unscrew the lantern (4) from the actuator (7) (use a hook wrench).
- Remove the O-rings (D4) and (D5) from lantern (4).

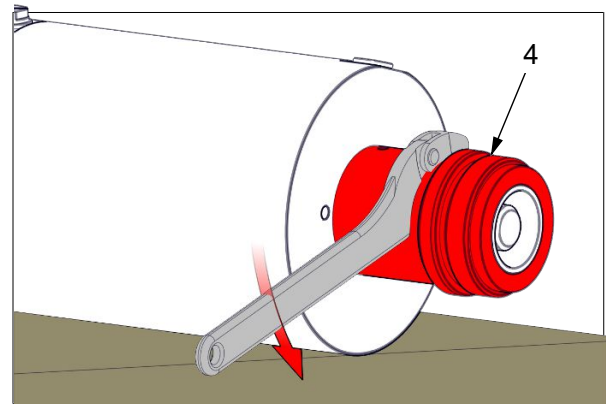

- Unscrew the insert (8) from the actuator (7) (use a hook wrench).
- Remove the O-rings (D4) and (D5).

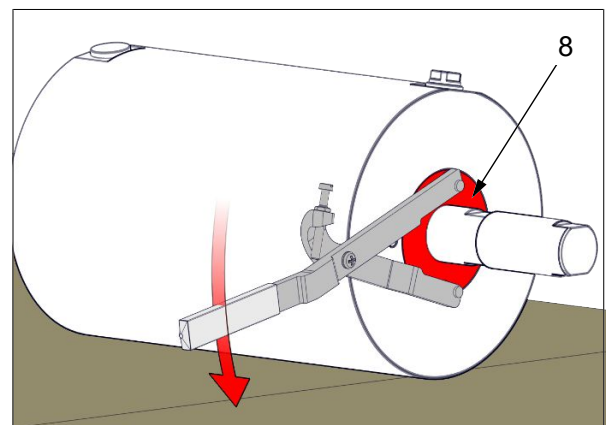

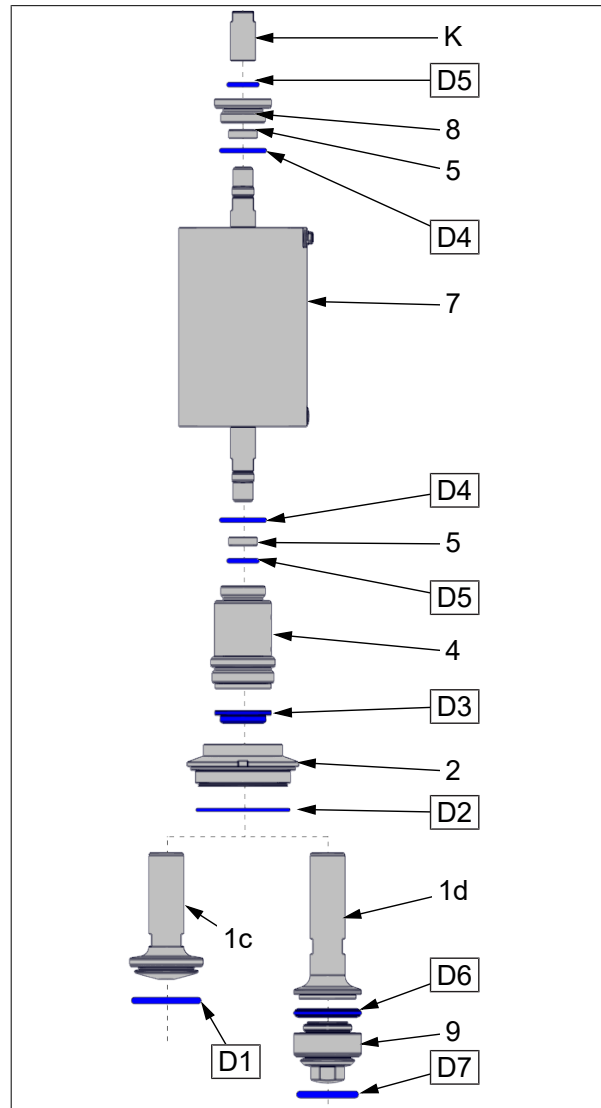



### 8.3 Tank outlet valve

#### Assembly valve insert

- Connect compressed air to LA2 and pressurize the actuator with air.
  - The piston retracts.

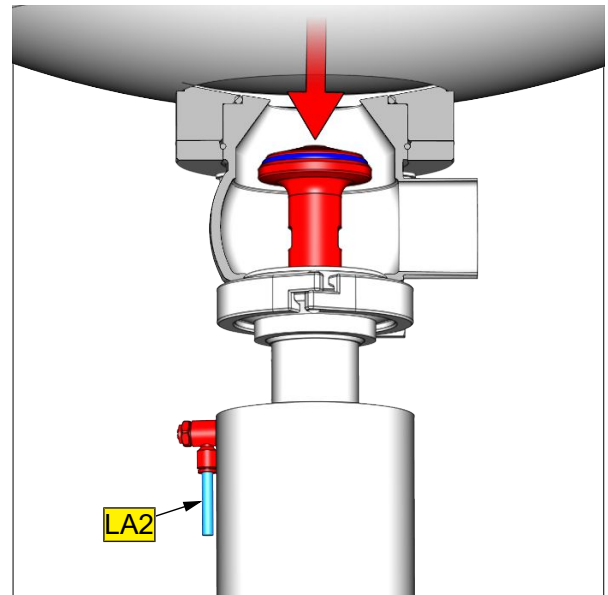

- Unscrew the clamp coupling (VK).
- Remove the complete valve insert with the upper shaft seal (D1) from the housing (VG).
- Disconnect compressed air at LA2 and depressurize the drive - The valve piston move in.
  - The valve piston returns to the basic position.

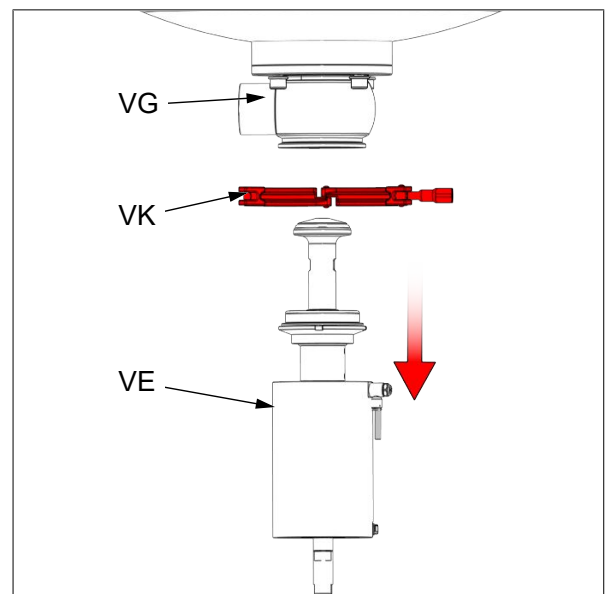

**Replacement wear parts - Valve housing (VG)**

- Unscrew the screw (FL-S).
- Remove valve housing (VG) with flange (FL2) and O-ring (FL-D).
- Dismantling circlip ring (FL-SR) and flange (FL2) from the housing (VG).

**NOTICE!** Information for the "Disassembly of the valve insert" can be found under Tank outlet valve [▶ 25]

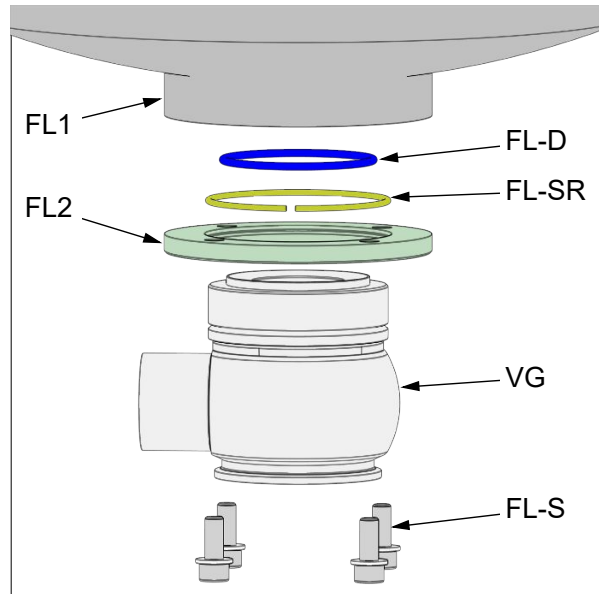

# 9 Drawings and dimensions

## 9.1 Drawings

Angle valve, Two way valves

K = Cap

VE = Valve insert

- 1.1 = Angle valve pneumatical
- 1.2 = Changeover valve pneumatical
- 2.1 = angle valve manual
- 2.2 = Changeover valve manual

VK = Clamp coupling

VG = Valve housing

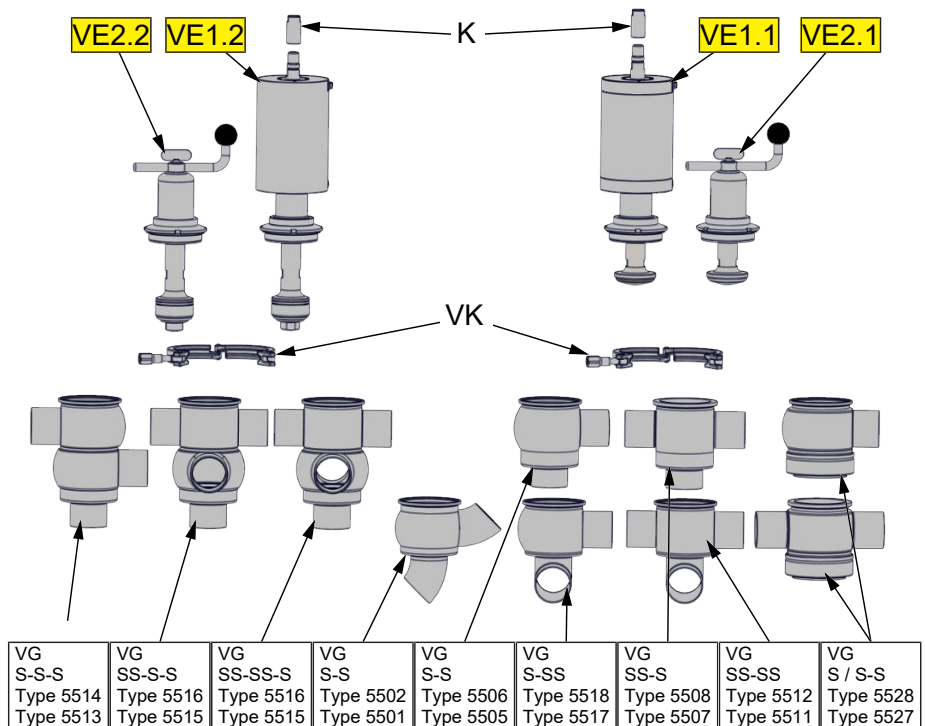

Tank outlet valve

FL1 = Tank flange<sup>1</sup>

FL2 = Housing flange

FL-D = O-ring<sup>1</sup>

FL-S = Screw

FL-SR = Retaining ring

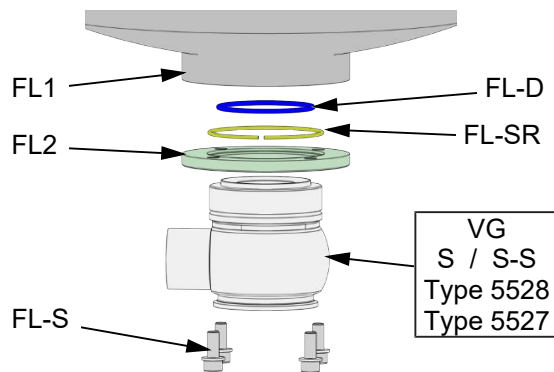

### Valve inserts (VE)

manual DN50

- Insert for angle valves Type: 5505
- Insert for changeover valves Type: 5513

pneumatical DN50

- Insert for angle valves Type: 5506
- Insert for changeover valves Type: 5514

1 = Piston

- a = angle valve manual
- b = Changeover valve manual
- c = Angle valve pneumatical
- d = Changeover valve pneumatical

2 = Insert

3 = Bearing bush

4 = Lantern

5 = Bearing bush

6 = Spindle

7 = Pneum. actuator

8 = Insert - Lantern

9 = Piston plate

10 = Set screw

11 = Spindle

12 = Bearing bush

13 = Scraper ring

14 = housing cover

D1 = O-ring

D2 = O-ring

D3 = Shaft seal

D4 = O-rings

D5 = O-rings

D6 = Seal

D7 = O-ring

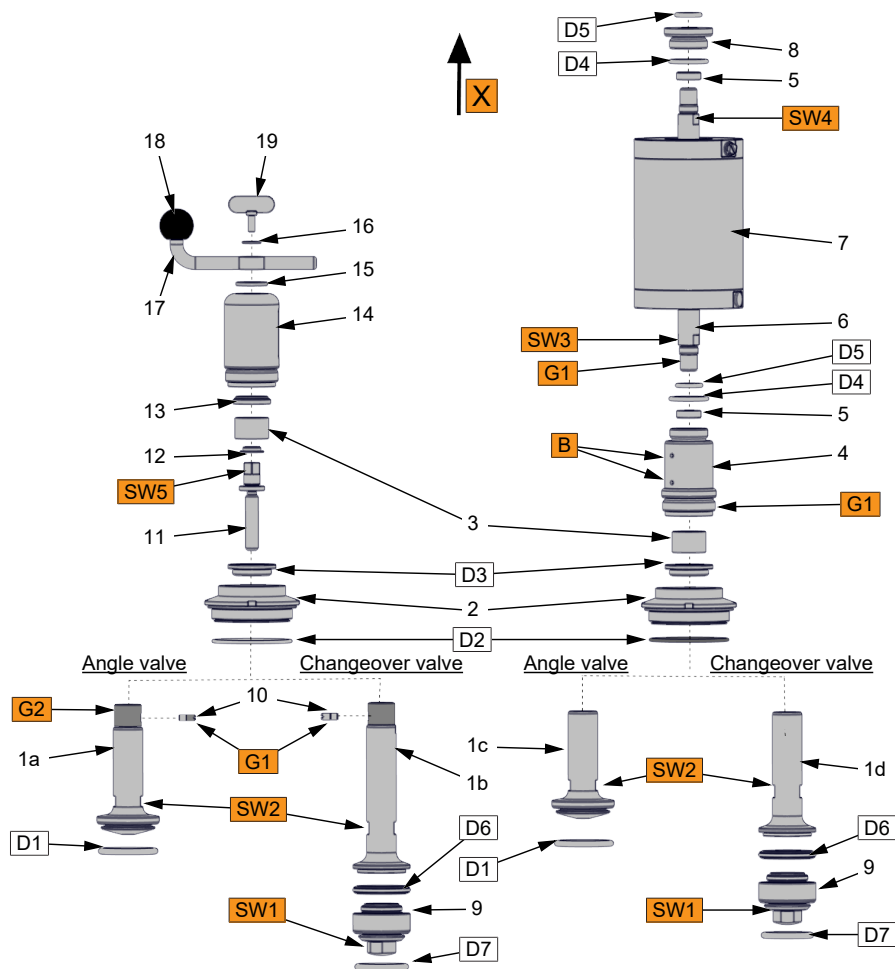

Nominal diameter	Wrench size					Hinged hook wrench		Joint face wrench
	SW1	SW2	SW3	SW4	SW5	Form A (hook)	Form B (pin)	D 40-80mm Pin Ø5 / Ø6
DN 25 / 1"	19	24	17	17	11	Form A DN 25-100: 8028025100-020	Form A DN125: 8028025150-020	Ø4 (to 2015)8028340085-000
DN 40 / 1½"	24							
DN 50 / 2"	24							
DN 65 / 2½"	36							
DN 80 / 3"	27							
DN 100 / 4"	27							
DN 125 / 5"	27	Form B (to 2015) Ø4: 8027000060-000		Form B (from 2015) Ø6: 8027000065-000		Ø6 (from 2015)8028340080-000		

## 9.2 Dimensions

### Housing

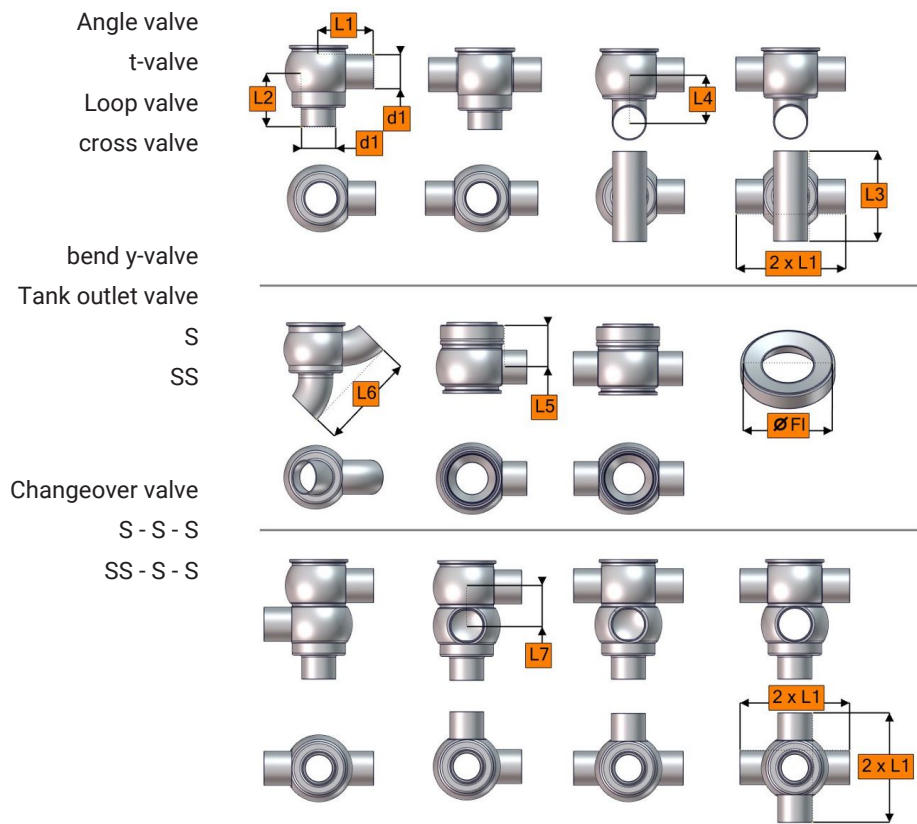

Nominal diameter	d1	L1	L2	L3	L4	L5	L6	L7	ø FI
DN 25 1 Inch	Ø 29 x 1,5 Ø25.4x1.65	75	75	100	57	70.5	126	36 32	ø 100
DN 40 1½ Inch	Ø 41 x 1,5 Ø31.8x1.65	85	85	120	66	70.5	138	48 45	ø 125
DN 50 2 Inch	Ø 53 x 1,5 Ø50,8 x 1,65	85	85	140	74.5	69.5	150	60 57.5	ø 138
DN 65 2½ Inch	Ø 70 x 2,0 Ø63,5 x 1,65	105	105	160	96	78.5	185	76 70	ø 165
DN 80 3 Inch	Ø 85 x 2,0 Ø76,1 x 2,0	115	115	180	122	101.5	219	91 83	ø 176
DN 100 4 Inch	Ø 104 x 2,0 Ø101,6 x 2,0	130	130	200	144	120	247	110 108	ø 209
DN 125 5 Inch	Ø 129 x 2,0 Ø 127 x 2,0	-	-	-	-	-	-	- -	ø 238

**Angle valve, T-valve, Loop valve, Cross valve**

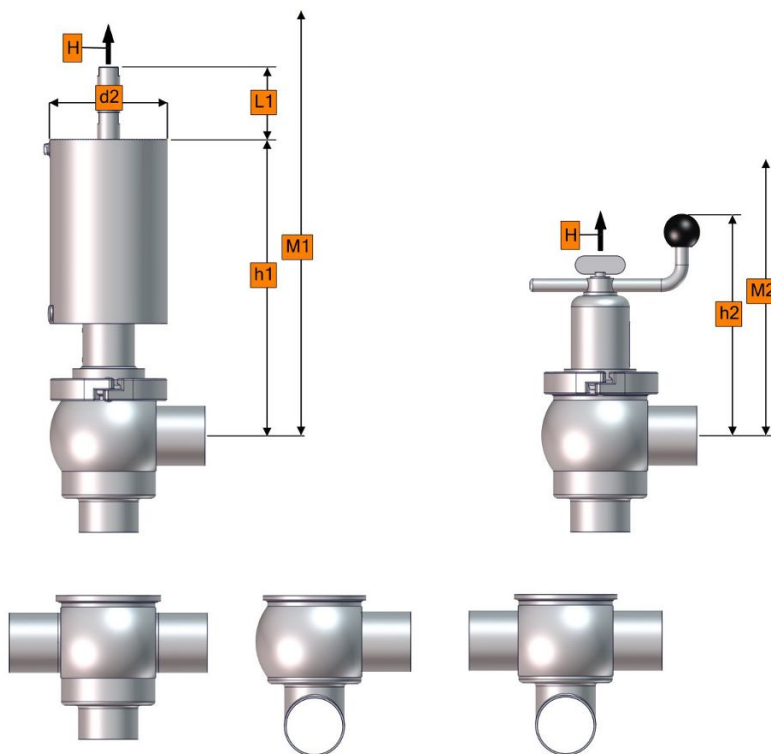

Nominal diameter	d2	h1	h2	M1 <sup>1</sup>	M2	L1		H (stroke)	
				Size when completed	NC	NO	pneum.	manual	
DN 25 1 Inch	ø 104	249	184	~ 440	~ 240	82	93	18	14
		248				86	93	14	10
DN 40 1½ Inch	ø 104	255	190	~ 460	~ 255	70	93	30	25
		253.5				7305	93	26.5	22.5
DN 50 2 Inch	ø 104	261	196	~ 480	~ 280	69	93	24	26
		260.5				61.5	93	21.5	23.5
DN 65 2½ Inch	ø 129	269	204	~ 515	~ 310	69	93	24	26
		266				75	93	18	20
DN 80 3 Inch	ø 167	276.5	211	~ 540	~ 310	64.5	93	28.5	30.5
		272.5				64.5	93	28.5	21.5
DN 100 4 Inch	ø 167	286	221	~ 565	~ 370	64.5	93	28.5	30.5
		285				67	93	26	28
DN 125 5 Inch	-	-	-	-	-	-	-	-	-

Valves that do not meet the catalogue standards, can lead to dimensional deviations.

1. Installation dimension M1 are incl. control head or feedback unit

### Inclined seat valve

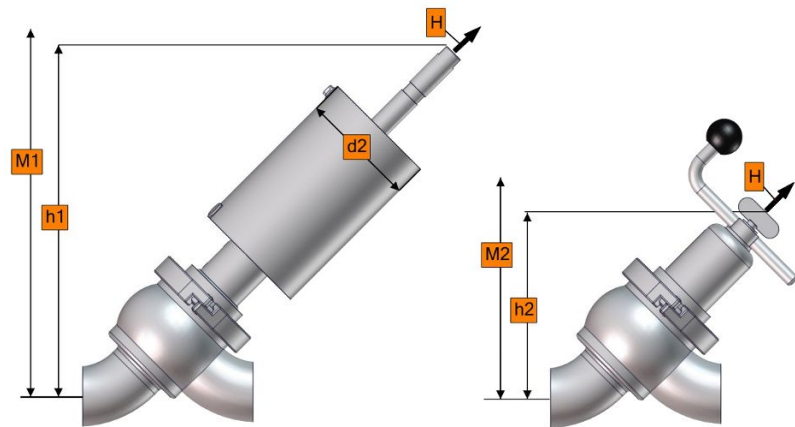

Nominal diameter	d2	h1		h2	M1 <sup>1</sup>	M2	H (stroke)	
		NC	NO				Size when completed	pneum.
DN 25 1 Inch	ø 104	277 -	291 -	147 -	~ 330	~ 266	18 14	14 10
DN 40 1½ Inch	ø 104	275 -	298 -	153 -	~ 370	~ 281	30 26.5	25 22.5
DN 50 2 Inch	ø 104	282 -	305 -	160 -	~ 390	~ 299	24 21.5	26 23.5
DN 65 2½ Inch	ø 129	298 -	321 -	177 -	~ 440	~ 331	24 18	26 20
DN 80 3 Inch	ø 167	311 -	338 -	193 -	~ 450	~ 358	28.5 28.5	30.5 21.5
DN 100 4 Inch	ø 167	330 -	357 -	212 -	~ 500	~ 394	28.5 26	30.5 28
DN 125 5 Inch	-	-	-	-	-	-	-	-

Valves that do not meet the catalogue standards, can lead to dimensional deviations.

1. Installation dimension M1 are incl. control head or feedback unit

## Tank outlet valve

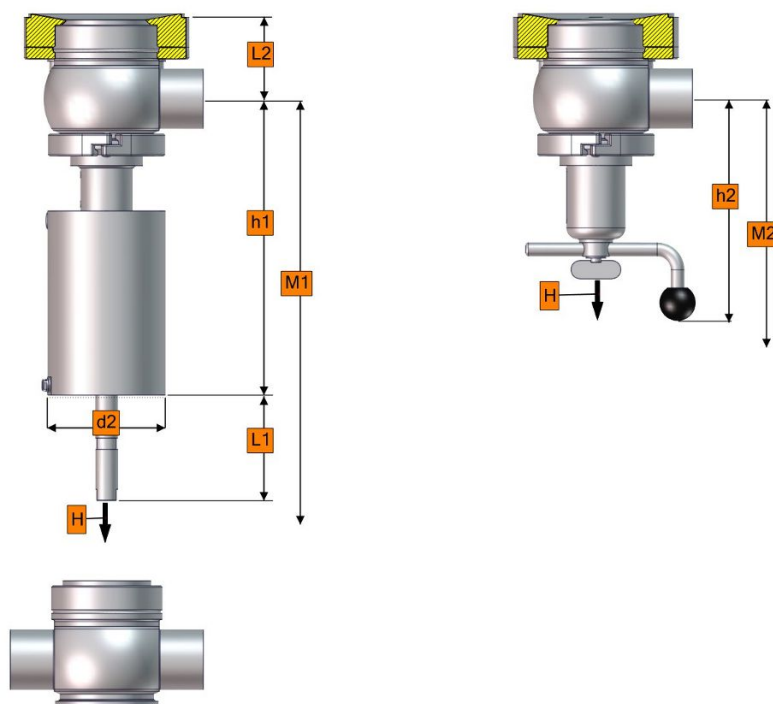

Nominal diameter	d2	h1	h2	M1 <sup>1</sup>	M2	L1		H (stroke)	
				Size when completed	NC	NO	pneum.	manual	
DN 25 1 Inch	ø 104	249 -	184 -	~ 490	~ 355	82 -	93 -	18 -	14 -
DN 40 1½ Inch	ø 104	255 -	190 -	~ 500	~ 365	70 -	93 -	30 -	25 -
DN 50 2 Inch	ø 104	261 -	196 -	~ 510	~ 380	69 -	93 -	24 -	26 -
DN 65 2½ Inch	ø 129	269 -	204 -	~ 550	~ 425	69 -	93 -	24 -	26 -
DN 80 3 Inch	ø 167	276.5 -	211 -	~ 580	~ 485	64.5 -	93 -	28.5 -	30.5 -
DN 100 4 Inch	ø 167	286 -	221 -	~ 630	~ 545	64.5 -	93 -	28.5 -	30.5 -
DN 125 5 Inch	-	-	-	-	-	-	-	-	-

Valves that do not meet the catalogue standards, can lead to dimensional deviations.

1. Installation dimension M1 are incl. control head or feedback unit



### 9.3 Control units

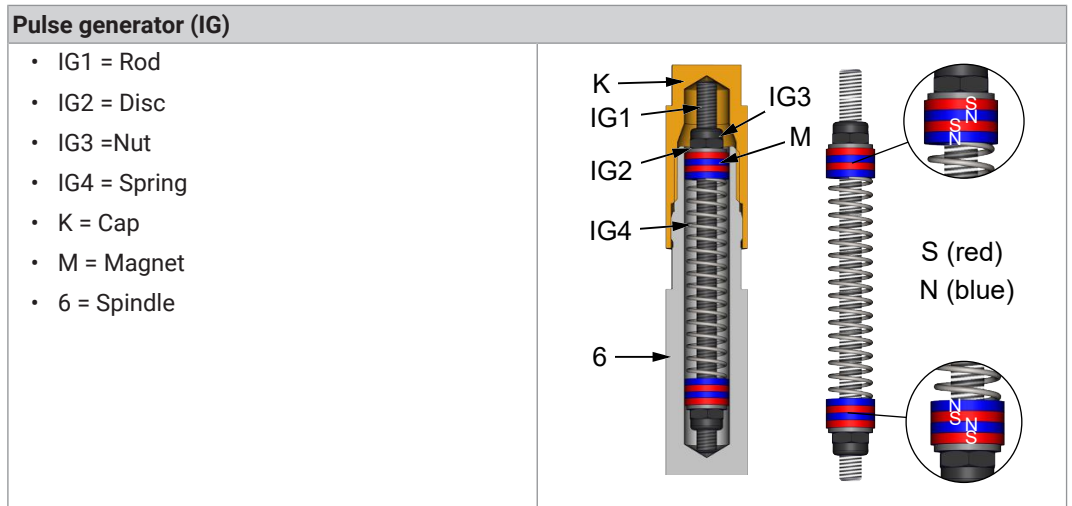
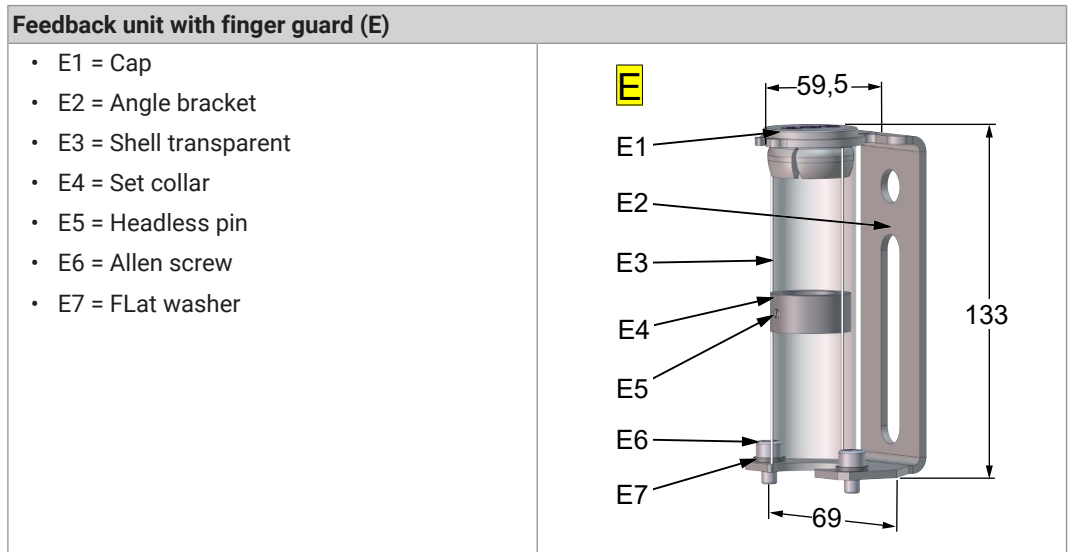
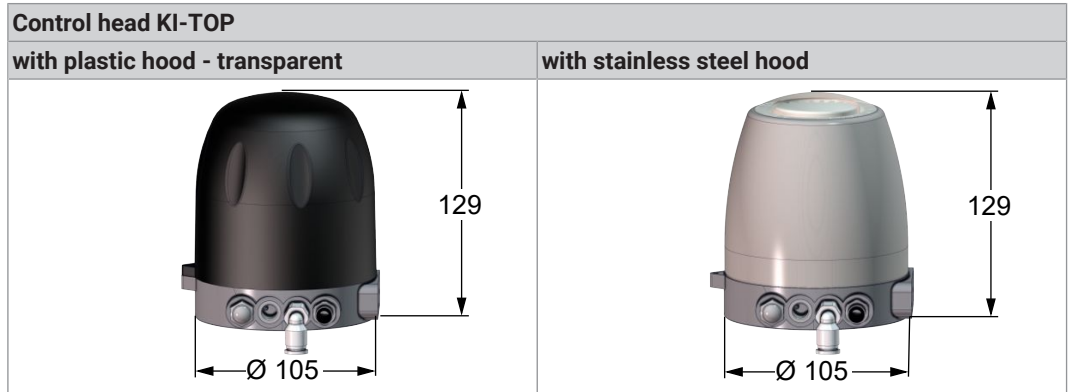

## 10 Wearing parts

### 10.1 Wearing parts list

#### DN 25 - DN 50 / 1 Inch - 2 Inch

Pos.	Material	pce.	DN 25 1 Inch	DN 40 1½ Inch	DN 50 2Inch
3	XSM	1x	Bearing bush 8050 028 020-156		
5	XSM	1x	Bearing 8050 020 007-156		
13	NBR	1x	Scraper ring 2330 028 007-055		
D1	EPDM	1x	O-ring 2304 041 035-159		O-ring 2304 044 053-159
	HNBR	1x	2304 041 035-157		2304 044 053-157
	FKM	1x	2304 041 035-178		2304 044 053-178
D2	EPDM	1x	O-ring 2304 069 026-159		
	HNBR	1x	2304 069 028-050		
	FKM	1x	2304 069 026-251		
D3	EPDM	1x	Seal 5506 050 009-054		
	HNBR	1x	Seal 5506 050 009-050		
	FKM	1x	Seal 5506 050 009-251		
D4	NBR	2x	O-ring 2304 030 035-055		
D5	HNBR	2x	O-ring 2304 019 035-171		
D6	EPDM		Seal		
	- complete	1x	5621 055 025-084		
	- Jacket	1x	5621 055 026-084		
	- Support ring	1x	5621 055 027-020		
	HNBR		Seal		
	- complete	1x	5621 055 025-171		
- Jacket	1x	5621 055 026-171			
- Support ring	1x	5621 055 027-020			
	FKM		Seal		
	- complete	1x	5621 055 025-251		
	- Jacket	1x	5621 055 026-251		
	- Support ring	1x	5621 055 027-020		
D7	EPDM	1x	O-ring 2304 038 053-170		
	HNBR	1x	2304 038 053-171		
	FKM	1x	2304 038 053-178		
FL-D	EPDM	1x	O-ring 2304 057 035-054	O-ring 2304 063 053-170	O-ring 2304 075 040-054
	HNBR/NBR	1x	2304 057 035-050	2304 063 053-050	2304 075 040-055

Seal (D6) = New version with support ring

**DN 65 - DN 100 / 2½ Inch - 3 Inch**

Pos.	Material	pce.	DN 65 2½ Inch	DN 80 3 Inch	DN 100 4Inch
3	XSM	1x	Bearing bush 8050 028 020-156		
5	XSM	1x	Bearing 8050 020 007-156		
13	NBR	1x	Scraper ring 2330 028 007-055		
D1			O-ring	O-ring	O-ring
	EPDM	1x	2304 053 053-159	2304 069 053-159	2304 088 053-159
	HNBR	1x	2304 053 053-157	2304 069 053-157	2304 088 053-157
	FKM	1x	2304 053 053-178	2304 069 053-178	2304 088 053-178
D2			O-ring	O-ring	O-ring
	EPDM	1x	2304 082 026-159	2304 098 035-159	2304 117 035-159
	HNBR	1x	2304 082 026-050	2304 098 035-050	2304 117 035-050
	FKM	1x	2304 082 026-051	2304 098 035-051	2304 117 035-051
D3	EPDM	1x	Seal 5506 050 009-054		
	HNBR	1x	Seal 5506 050 009-050		
	FKM	1x	Seal 5506 050 009-251		
D4	NBR	2x	O-ring 2304 030 035-055		
D5	HNBR	2x	O-ring 2304 019 035-171		
D6	EPDM		Seal	Seal	
	- complete	1x	5621 065 025-084	5621 100 025-084	
	- Jacket	1x	5621 065 026-084	5621 100 026-084	
	- Support ring	1x	5621 065 027-020	5621 100 027-020	
	HNBR		Seal	Seal	
	- complete	1x	5621 065 025-171	5621 100 025-171	
	- Jacket	1x	5621 065 026-171	5621 100 026-171	
	- Support ring	1x	5621 065 027-020	5621 100 027-020	
	FKM		Seal	Seal	
- complete	1x	5621 065 025-251	5621 100 025-251		
- Jacket	1x	5621 065 026-251	5621 100 026-251		
- Support ring	1x	5621 065 027-020	5621 100 027-020		
D7			O-ring	O-ring	O-ring
	EPDM	1x	2304 047 053-170	2304 069 053-159	2304 083 050-069
	HNBR	1x	2304 047 053-171	2304 069 053-157	2304 083 050-157
	FKM	1x	2304 047 053-178	2304 069 053-178	2304 083 050-178
FL-D			O-ring	O-ring	O-ring
	EPDM	1x	2304 090 040-170	2304 102 050-159	2304 133 053-159
	HNBR/NBR	1x	2304 090 040-050	2304 102 050-050	2304 133 053-050

Seal (D6) = New version with support ring

## 10.2 Wear parts kit

### Angle valve Type: 5505, 5506, 5507, 5508, 5511, 5512

Seals (D1), (D2), (D3)

	<b>DN 25</b> <b>1 Inch</b>	<b>DN 40</b> <b>1½ Inch</b>	<b>DN 50</b> <b>2Inch</b>
HNBR	5506 025 990-050	5506 040 990-050	5506 050 990-050
EPDM	5506 025 990-054	5506 040 990-054	5506 050 990-054
FKM	5506 025 990-251	5506 040 990-251	5506 050 990-251

	<b>DN 65</b> <b>2½ Inch</b>	<b>DN 80</b> <b>3 Inch</b>	<b>DN 100</b> <b>4Inch</b>
HNBR	5506 065 990-050	5506 080 990-050	5506 100 990-050
EPDM	5506 065 990-054	5506 080 990-054	5506 100 990-054
FKM	5506 065 990-251	5506 080 990-251	5506 100 990-251

### Two way valves Type: 5513, 5514, 5515, 5516

Seals (D2), (D3), (D6), (D7)

	<b>DN 25</b> <b>1 Inch</b>	<b>DN 40</b> <b>1½ Inch</b>	<b>DN 50</b> <b>2Inch</b>
HNBR	5514 050 990-050	5514 050 990-050	5514 050 990-050
EPDM	5514 050 990-054	5514 050 990-054	5514 050 990-054
FKM	5514 050 990-251	5514 050 990-251	5514 050 990-251

	<b>DN 65</b> <b>2½ Inch</b>	<b>DN 80</b> <b>3 Inch</b>	<b>DN 100</b> <b>4Inch</b>
HNBR	5514 065 990-050	5514 080 990-050	5514 100 990-050
EPDM	5514 065 990-054	5514 080 990-054	5514 100 990-054
FKM	5514 065 990-251	5514 080 990-251	5514 100 990-251

Seal (D6) without support ring

**Tank outlet valve Typ: 5527, 5528**

Seals (D1), (D2), (D3), (D6)

	<b>DN 25</b> <b>1 Inch</b>	<b>DN 40</b> <b>1½ Inch</b>	<b>DN 50</b> <b>2Inch</b>
HNBR	5528 050 990-050	5528 050 990-050	5528 050 990-050
EPDM	5528 050 990-054	5528 050 990-054	5528 050 990-054
FKM	5528 050 990-251	5528 050 990-251	5528 050 990-251

	<b>DN 65</b> <b>2½ Inch</b>	<b>DN 80</b> <b>3 Inch</b>	<b>DN 100</b> <b>4Inch</b>
HNBR	5528 065 990-050	5528 080 990-050	5528 100 990-050
EPDM	5528 065 990-054	5528 080 990-054	5528 100 990-054
FKM	5528 065 990-251	5528 080 990-251	5528 100 990-251

<b>Pos.</b>	<b>Material</b>	<b>pce.</b>	<b>DN 25</b> <b>1 Inch</b>	<b>DN 40</b> <b>1½ Inch</b>	<b>DN 50</b> <b>2Inch</b>
FL1	1.4404 AISI316L	1x	5727 025 001-040	5727 040 001-040	5727 050 001-040
FL-D	EPDM HNBR/NBR	1x	O-ring 2304 057 035-054	O-ring 2304 063 053-170	O-ring 2304 075 040-054
		1x	2304 057 035-050	2304 063 053-050	2304 075 040-055

<b>Pos.</b>	<b>Material</b>	<b>pce.</b>	<b>DN 65</b> <b>2½ Inch</b>	<b>DN 80</b> <b>3 Inch</b>	<b>DN 100</b> <b>4Inch</b>
FL1	1.4404 AISI316L	1x	5727 065 001-040	5727 080 001-040	5727 100 001-040
FL-D	EPDM HNBR/NBR	1x	O-ring 2304 090 040-170	O-ring 2304 102 050-159	O-ring 2304 133 053-159
		1x	2304 090 040-050	2304 102 050-050	2304 133 053-050

# 11 Classification

## 11.1 Structure of Order Number

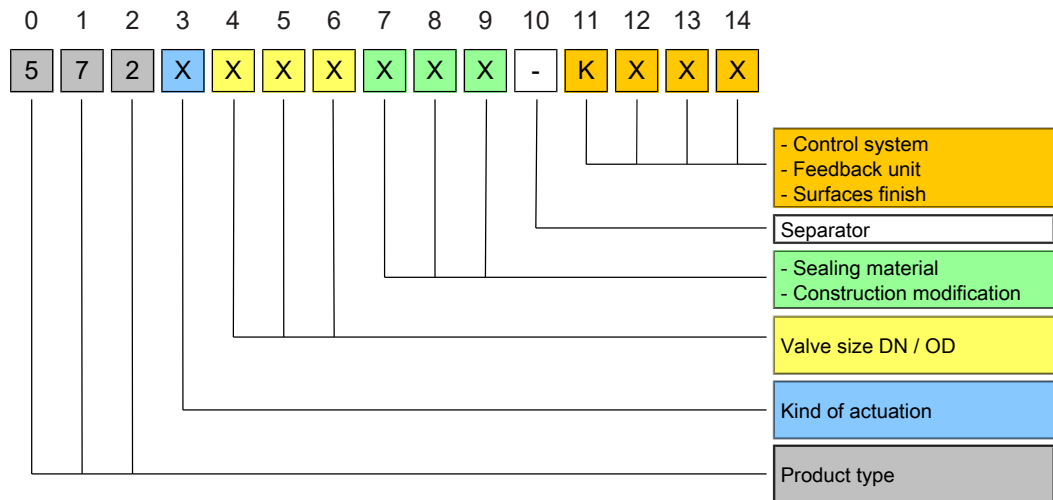

Product name

55xx xxx xxx-xxxx

Type: 55xx Single seat valves KI-DS

Housing type / Kind of actuation

55xx xxx xxx-xxxx

Type	Housing type	Kind of actuation	2	3
5501	S-S Inclined seat valve	manual	0	1
5502		pneumatical	0	2
5505	S-S Angle valve	manual	0	5
5506		pneumatical	0	6
5507	SS-S T-valve	manual	0	7
5508		pneumatical	0	8
5511	SS-SS Cross valve	manual	1	1
5512		pneumatical	1	2
5513	S-S-S Changeover valve	manual	1	3
5514		pneumatical	1	4
5515	SS-S-S Changeover valve	manual	1	5
5516		pneumatical	1	6
5517	S-SS Loop valve	manual	1	7
5518		pneumatical	1	8
5527	S Tank outlet valve	manual	2	7
5528	SS Tank outlet valve	manual	2	7
	S Tank outlet valve	pneumatical	2	8
	SS Tank outlet valve	pneumatical	2	8

**Valve size DN/OD**

55xx xxx xxx-xxxx

DN	4	5	6	OD	4	5	6
DN 25	0	2	5	OD 1"	0	2	6
DN 40	0	4	0	OD 1 1/2"	0	3	8
DN 50	0	5	0	OD 2"	0	5	1
DN 65	0	6	5	OD 2 1/2"	0	6	4
DN 80	0	8	0	OD 3"	0	7	6
DN 100	1	0	0	OD 4"	1	0	1
DN 125	1	2	5	OD 5"	1	2	7
DN 150	1	5	0	OD 6"	1	5	2

**Material of seal & Design modification**

55xx xxx xxx-xxxx

Material of seals & Design modifica				7	8	9
Type	Housing	Variations of actuation	Seal			
5501, 5502	S-S	Normally closed (NC)	EPDM	0	3	0
5505, 5506	S-S		HNBR	0	3	5
5507, 5508	SS-S		FKM	0	3	4
5511, 5512	SS-SS	Normally open (NO)	EPDM	1	3	0
5513, 5514	S-SS		HNBR	1	3	5
5515, 5516	S-S-S		FKM	1	3	4
5517, 5518	SS-S-S	air open - air close (DA)	EPDM	3	3	0
5527; 5528	S		HNBR	3	3	5
			FKM	3	3	4
5527, 5528	SS	Normally closed (NC)	EPDM	2	3	0
			HNBR	2	3	5
			FKM	2	3	4

Separator

55xx xxx xxx-xxxx

- KIESELMANN Valve

**Control system and position indication , External surface**

55xx xxx xxx-xxxx

Control system and position indicator	11	12	13	14
Control head SPS (old version)	5	x	x	
Control head ASi-Bus (old version)	6	x	x	
Control head KI-Top SPS	K	5	x	x
Control head KI-Top ASi-Bus	K	6	x	x

Feedback unit	11	12	13	14
Feedback unit with finger guard (5630 005 025-000)	7	5	0	

External surface	11	12	13	14
Valve without control system External surface: AISI304, blank	0	2	0	
Valve without control system External surface AISI304, E-polished	0	2	1	
Valve without control system External surface AISI316L, E-polished	0	4	1	

## 12 Appendix

### 12.1 Declaration of incorporation



#### CE Declaration of incorporation

Translation of the original

Manufacturer / authorised representative:	Guth Ventiltechnik GmbH Horstring 16 76829 Landau Germany
Authorised representative, for compiling technical documents:	Achim Kauselmann Documentation / Development KIESELMANN GmbH

<u>Product</u>	<u>Function</u>
pneum. Lift actuators	Stroke movement
pneum. Rotary actuators	Rotary movement
Ball valves	Media cutoff
Butterfly valves	Media cutoff
Single seat valves	Media cutoff
Flow control valves	Control of liquefied media
Throttle valve	Control of liquefied media
Overflow valve	Definition of fluid pressure
Double seat valve	Media separation
Bellow valves	Sampling of liquids
Sampling valves	Sampling of liquids
Two way valves	Media cutoff
Tankdome fitting	Prevention of overpressure and vacuum, Tank cleaning
Safety valve	Prevention of overpressure

The manufacturer hereby states that the above product is considered as an incomplete machine in the sense defined in the Directive 2006/42/EC on Machinery. The above product is exclusively intended to be installed into a machine or an incomplete machine. The said product does not yet conform to all the relevant requirements defined in the Directive on Machinery referred to above for this reason.

The specific technical documents listed in Appendix VII, Part B, have been prepared. The Authorized Agent empowered to compile technical documents may submit the relevant documents if such a request has been properly justified.

Commissioning of an incomplete machine must not only be carried out if it has been determined that the respective machine into which the incomplete machine is to be installed conforms to the regulations set out in the Directive on Machinery referred to above.

The above product conforms to the requirements of the directives and harmonized standards specified below:

- Directive 2014/68/EU
- DIN EN ISO 12100 Safety of machinery

Landau, 01.07.2016

  
Jens Klene  
General Manager