

Operating instructions

- Translation of the original -

Multiturn actuator

Type: 4x00

pneumatic - mechanical
for butterfly valves and ball valves



English **GBR**



Guth Ventiltechnik GmbH

Horstring 16
D - 76829 Landau

☎ +49 (0) 6341 5105-0 ♦ Fax: +49 (0) 6341 5105-85
www.guth-vt.de ♦ sales@guthventiltechnik.de

List of contents

1.	General information	2
1.1	Information for your safety	2
1.2	Marking of security instructions in the operating manual	2
1.3	Designated use	2
1.4	Personnel	2
1.5	Modifications, spare parts, accessories	2
1.6	General instructions	2
2.	Safety instructions	3
2.1	Intended use	3
2.2	General safety instructions	3
2.3	General notes	3
3.	Function and Operation	4
3.1	Description of function	4
3.2	Control system - and interrogation system.....	4
3.3	Field of application	5
3.4	Installation instructions.....	5
3.5	ATEX-Guidelines	5
3.6	Service and Maintenance	5
3.7	Technical Data	6
3.8	Torque characteristic	7
4.	Dimensions.....	8
5.	Spare parts list	9
6.	Declaration of incorporation	10

1. General information

1.1 Information for your safety

We are pleased that you have decided for a high-class GUTH product. With correct application and adequate maintenance, our products provide long time and reliable operation.





Before installation and initiation, please carefully read this instruction manual and the security advices contained in it. This guarantees reliable and safe operation of this product and your plant respectively. Please note that an incorrect application of the process components may lead to great material damages and personal injury.

In case of damages caused by non observance of this instruction manual, incorrect initiation, handling or external interference, guarantee and warranty will lapse!

Our products are produced, mounted and tested with high diligence. However, if there is still a reason for complaint, we will naturally try to give you entire satisfaction within the scope of our warranty. We will be at your disposal also after expiration of the warranty. In addition, you will also find all necessary instructions and spare part data for maintenance in this instruction manual. If you don't want to carry out the maintenance by yourself, our GUTH service team will naturally be at your disposal.

1.2 Marking of security instructions in the operating manual

Hints are available in the chapter "safety instructions" or directly before the respective operation instruction. The hints are highlighted with a danger symbol and a signal word. Texts beside these symbols have to be read and adhered to by all means. Please continue with the text and with the handling at the valve only afterwards.

Symbol	Signal word	Meaning
	DANGER	Imminent danger which <u>will result</u> severe personal injury or death.
	WARNING	Imminent danger which <u>may result</u> severe personal injury or death.
	CAUTION	Dangerous situation which may cause slight personal injury or material damages.
	ATTENTION	An harmful situation which may result in damages of the product itself or of adjacent vicinity.
	NOTICE	Marks application hints and other information which is particularly useful.

1.3 Designated use

The fitting is designed exclusively for the purposes described below. Using the fitting for purposes other than those mentioned is considered contrary to its designated use. GUTH cannot be held liable for any damage resulting from such use. The risk of such misuse lies entirely with the user. The prerequisite for the reliable and safe operation of the fitting is proper transportation and storage as well as competent installation and assembly. Operating the fitting within the limits of its designated use also involves observing the operating, inspection and maintenance instructions.

1.4 Personnel

Personnel entrusted with the operation and maintenance of the tank safety system must have the suitable qualification to carry out their tasks. They must be informed about possible dangers and must understand and observe the safety instructions given in the relevant manual. Only allow qualified personnel to make electrical connections.

1.5 Modifications, spare parts, accessories

Unauthorized modifications, additions or conversions which affect the safety of the fitting are not permitted. Safety devices must not be bypassed, removed or made inactive. Only use original spare parts and accessories recommended by the manufacturer.

1.6 General instructions

The user is obliged to operate the fitting only when it is in good working order. In addition to the instructions given in the operating manual, please observe the relevant accident prevention regulations, generally accepted safety regulations, regulations effective in the country of installation, working and safety instructions effective in the user's plant.

2. Safety instructions

2.1 Intended use

The pneumatic rotary drive can be used for rotary fittings in the beverages and foodstuffs industry, the pharmaceuticals industry and the bio-technology sector, as well as the chemical industry.

2.2 General safety instructions



ATTENTION

- To avoid danger and damage, the fitting must be used in accordance with the safety instructions and technical data contained in the operating instructions.



WARNING

- Danger of injury by spring tension! The drive is maintenance-free. Do not open it.
- For valves or plants/installations that are operated in a ATEX area, must be considered the valid ATEX Guidelines EG and the Installation instructions (3.5 /page 5).



CAUTION

- To avoid air leaking, only use pneumatic connection parts that have an O-ring seal facing the even surface.
- Steps should be taken to ensure that no external forces are exerted on the fitting.

2.3 General notes



NOTICE

- All data are in line with the current state of development. Subject to change as a result of technical progress.

3. Function and Operation

3.1 Description of function

➤ air open - spring close

Clockwise

If compressed air is connected to the air connection port LA1 of the rotary drive (A), its axis will turn 90° clockwise. When bleeding it will reset by spring force. (Art-No. 4200 xxx x00-022)

Counter-clockwise

If compressed air is connected to the air connection port LA2 of the rotary drive (A), its axis will turn 90° counter-clockwise. When bleeding it will reset by spring force. (Art-No. 4200 xxx x00-G022)

➤ air open - air close

If compressed air is connected to the air connection port LA1 or LA2 of the rotary drive (A), its axis will turn 90° clockwise or counter-clockwise.

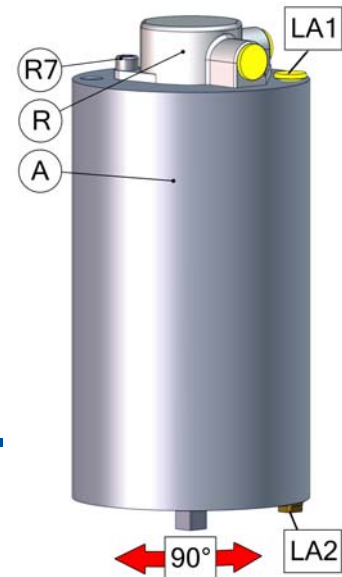

NOTICE

- To make sure that the rotary movement really stops at 0°-90° or 90°-0°, make sure to bleed the compressed air port of the rotary drive not being used.
- In order to avoid air leakages, only use an elbow-type screw-in connexion respectively a straight screw-in connexion with sealing by an o-ring to the end face.

3.2 Control system - and interrogation system

Standard equipment of the rotary drive (A) includes a position indication (R2).

➤ Proximity switches (Sensors)

The transparent hood (R5) is suitable for commercially available inductive proximity switches (sensors) with thread M12x1. Use proximity switches with non-flush mounting and a nominal operating distance of min. 4.0 mm.

GUTH have various variants of proximity switches available.

Assembly

NOTICE

- To prevent leaks, the thread needs to be sealed with a gasket strip when installing the proximity switches.

Before mounting proximity switches first remove the red plastic caps (R6) from the hood (R5). Then manually screw the proximity switches into the threadholes of the hood (R5) until they arrive at the stop. No adjustment will be required. Screw the locknut against the hood (R5) applying little force.

For valve maintenance you may screw the hood (R5) off the drive unit together with the proximity switches.

➤ Control head

Optionally, modular valve control systems can be installed to the actuator for reading and actuating valve positions. The standard version is a closed system with twofold limit position messaging (standard), with SPS, Interbus or ASI bus switch-on electronics, and integrated 3/2-way solenoid valves. For tough operating conditions we recommend employing a stainless steel hood.

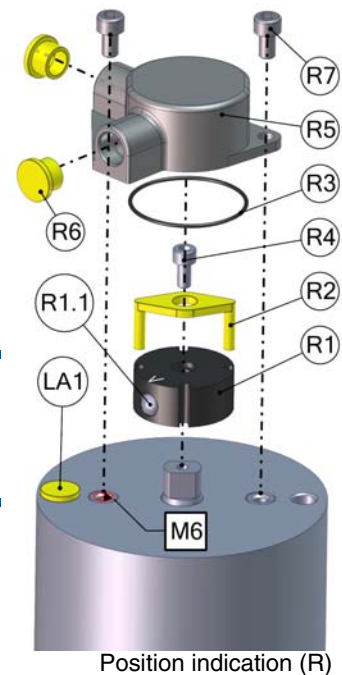

Position indication (R)



Control head

Position indication (R)

- R1) Dog
- R1.1) Pin
- R2) Position indicator
- R3) O-Ring
- R4) Screw
- R5) Hood transparent
- R6) Cap
- R7) Screw
- LA1) Air connection



3.3 Field of application

The rotary drive is used for the following KIESELMANN and GUTH - products:

- Butterfly valves (BV) and Leakage butterfly valves (LBV)
- Straight way ball valve (SWBV) and Three-way ball valve (TWBV)

Actuator	Type	Article No.	BV	LBV	SWBV	TWBV
90 / 75	lö-fs (air/spring) lö-fs L (air/spring)	4200 075 000-022 4200 075 000-G022	DN15 - 40	-	DN10 - 40	-
90 / 100	lö-ls (air/air) lö-fs (air/spring) lö-fs L (air/spring)	4100 100 000-022 4200 100 000-022 4200 100 000-G022	DN25 - 100	DN50 - 80	DN25 - 80	DN25 - 65
90 / 125	lö-ls (air/air) lö-fs (air/spring) lö-fs L (air/spring)	4100 125 000-022 4200 125 000-022 4200 125 000-G022	DN125 - 150	DN100 - 150	DN100	DN80 - 100

*lö = air open; ls = air close; fs = spring close; fō = spring open; L = Counter-clockwise (Left)
BV = Butterfly valve; LBV = Leakage butterfly valve, SWBV = Straight way ball valve, TWBV = Three-way ball valve*

3.4 Installation instructions

➤ Installation position

You can mount the rotary drive 90/100 and 90/125 in any position, however, you should check if the manufacture of the valve used gave particular mounting specifications. The rotary drive 90/75 should be installed vertically.



NOTICE

- You may have to restrict the pressure of the outlet air to avoid line shocks.



ATTENTION

- Impurities can cause damage to the seals and seals area. Clean inside areas prior to assembly.

3.5 ATEX-Guidelines

For valves or plants/installations that are operated in the ATEX area, sufficient bonding (grounding) must be ensured (see valid ATEX Guidelines EG).

3.6 Service and Maintenance

➤ Service

The actuators are free of maintenance and can't be dismantled. The manufacturer guarantees a running time of five years or 50.000 strokes.

➤ Cleaning

The cleaning of the external surfaces must be performed at regular intervals. The cleaning cycles are to be defined by the user.

3.7 Technical Data

Model:	Multiturn, pneumatic - mechanical enclosed type		
Kind of actuation:	air / air (double action) air / spring (single action)		
Angle of rotation:	90° +3°		
Valve size:	Actuator 90 / 75 Actuator 90 / 100 Actuator 90 / 125		
Temperature range:	Ambient temperature: +4°C bis +60°C		
Pneum. connection:	G 1/8		
Control air:	Control air pressure:	Quality of control air:	
	5,5 - 8,0 bar	ISO 8573-1 : 2001 quality class 3	
Material:	Stainless steel:	1.4301 / AISI304	
	Surfaces:	Ra 1,5 - 2,5µm e-polished	
	Seals:	NBR	
Air requirement per stroke: (at atmospheric pressure)	Actuator 90 / 75	air / spring	- 0,20 liter / bar
	Actuator 90 / 100		- 0,50 liter / bar
	Actuator 90 / 125		- 0,70 liter / bar
	Actuator 90 / 100	air / air	- 1,30 liter / bar
	Actuator 90 / 125		- 1,90 liter / bar

3.8 Torque characteristic

➤ 90/75 air/spring

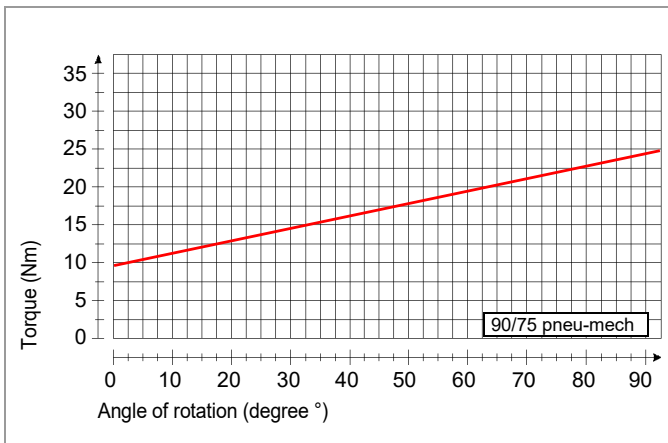

➤ 90/100 air/spring

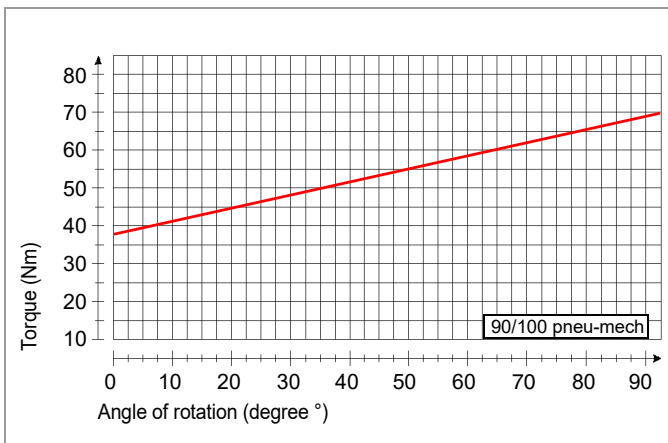

➤ 90/100 air/air

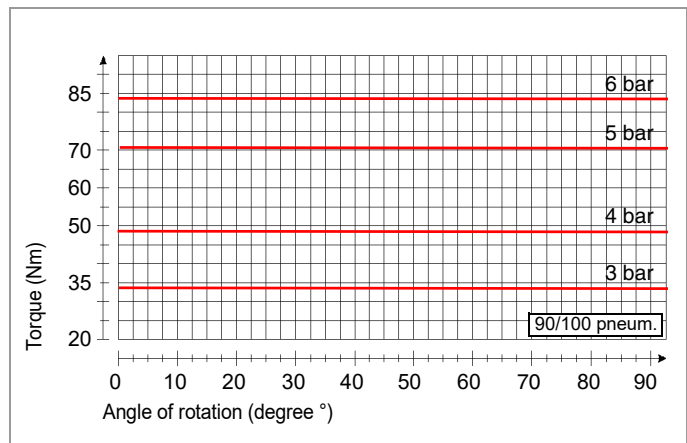

➤ 90/125 air/spring

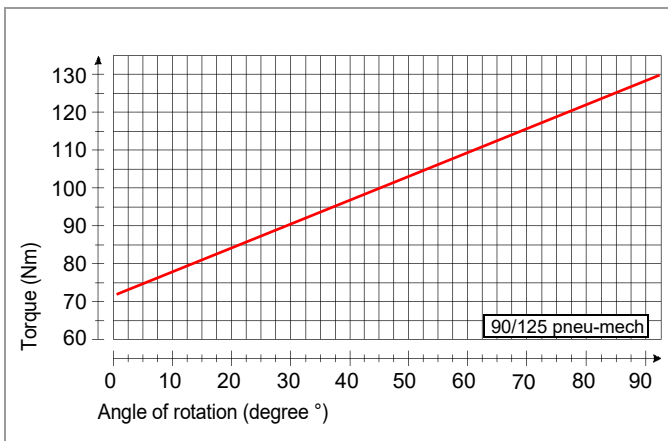

➤ 90/125 air/air

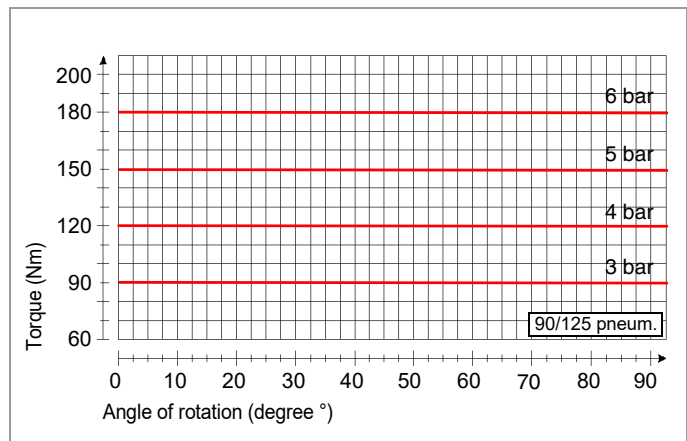

4. Dimensions

	Actuator		
	90 / 75	90 / 100	90 / 125
d	76	104	129
h1	142,5	186	215
h2	168	211,5	240,5
L1	56	56	78
L2	12	12	16
L3	14	14	20
M	8	8	8
LA	1/8	1/8	1/8
□	10	10	14

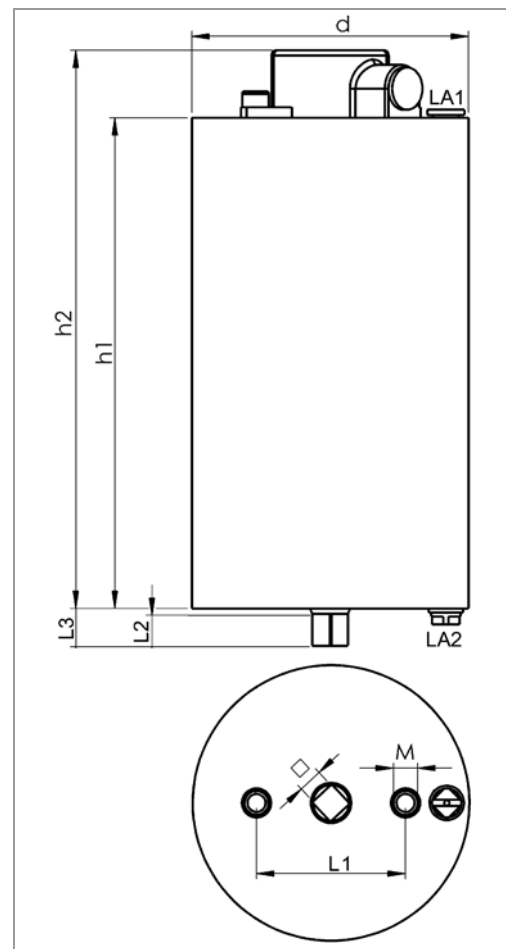



5. Spare parts list

► Actuator

Actuator	Type	Article No.	Material
90 / 75 (Ø 75)	lö-fs (air/spring)	4200 075 000-022	AISI304
	lö-fs L (air/spring)	4200 075 000-G022	
	lö-fs (air/spring) with sensor mounting	4200 075 100-022	
	lö-fs L (air/spring) with sensor mounting	4200 075 100-G022	
90 / 100 (Ø 104)	lö-ls (air/air)	4100 100 000-022	AISI304
	lö-ls (air/air) with sensor mounting	4100 100 100-022	
	lö-fs (air/spring)	4200 100 000-022	
	lö-fs L (air/spring)	4200 100 000-G022	
	lö-fs (air/spring) with sensor mounting	4200 100 100-022	
	lö-fs L (air/spring) with sensor mounting	4200 100 100-G022	
90 / 125 (Ø 125)	lö-ls (air/air)	4100 125 000-022	AISI304
	lö-ls (air/air) with sensor mounting	4100 125 100-022	
	lö-fs (air/spring)	4200 125 000-022	
	lö-fs L (air/spring)	4200 125 000-G022	
	lö-fs (air/spring) with sensor mounting	4200 125 100-022	
	lö-fs L (air/spring) with sensor mounting	4200 125 100-G022	

lö = air open; ls = air close; fs = spring close; fō = spring open; L = Counter-clockwise (Left)

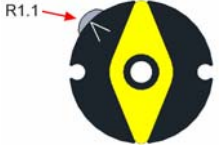
► Position indication (R) complete

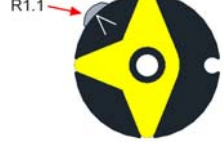
Valve type	Article No.	Position
<ul style="list-style-type: none"> Butterfly valve Leakage butterfly valve Straight way ball valve 	4100 100 020-000	
<ul style="list-style-type: none"> Three-way ball valve with L-ball 	4100 100 047-000	
<ul style="list-style-type: none"> Three-way ball valve with T-ball 	4100 100 040-000	

Pos.	Designation	Article No.	Material	Pce.
R1	Dog	4100 100 023-097	PBT sw	1
R1.1	Pin	8062 081 008-020	AISI304	1
R2	Position indicator	4100 100 024-093	PS rt	1
R3	O-Ring	2304 040 015-055	NBR 70°Sh.	1
R4	Screw	8095 005 010-020	AISI304	1
R5	Hood transparent	4100 100 021-094	MAPS	1
R6	Cap	4301 080 020-095	GPN 300/F091	2
R7	Screw	8095 006 010-020	AISI304	2



Declaration of incorporation

Translation of the original

Manufacturer / authorised representative:

Guth Ventiltechnik GmbH
Horstring 16
76829 Landau
Germany

Authorised representative,
for compiling technical documents:

Achim Kauselmann
Documentation / Development
KIESELMANN GmbH

Product

pneum. Lift actuators
pneum. Rotary actuators
Ball valves
Butterfly valves
Single seat valves
Flow control valves
Throttle valve
Overflow valve
Double seat valve
Bellow valves
Sampling valves
Two way valves
Tankdome fitting
Safety valve

Function

Stroke movement
Rotary movement
Media cutoff
Media cutoff
Media cutoff
Control of liquefied media
Control of liquefied media
Definition of fluid pressure
Media separation
Sampling of liquids
Sampling of liquids
Media cutoff
Prevention of overpressure and vacuum, Tank cleaning
Prevention of overpressure

The manufacturer hereby states that the above product is considered as an incomplete machine in the sense defined in the Directive 2006/42/EC on Machinery. The above product is exclusively intended to be installed into a machine or an incomplete machine. The said product does not yet conform to all the relevant requirements defined in the Directive on Machinery referred to above for this reason.

The specific technical documents listed in Appendix VII, Part B, have been prepared. The Authorized Agent empowered to compile technical documents may submit the relevant documents if such a request has been properly justified.

Commissioning of an incomplete machine must not only be carried out if it has been determined that the respective machine into which the incomplete machine is to be installed conforms to the regulations set out in the Directive on Machinery referred to above.

The above product conforms to the requirements of the directives and harmonized standards specified below:

- Directive 2014/68/EU
- DIN EN ISO 12100 Safety of machinery

Landau, 01.07.2016



Oliver Hecker
General Manager